

**CITY OF WEST ALLIS  
DEPARTMENT OF DEVELOPMENT  
FACADE DEMONSTRATION PROJECT  
COMMUNITY DEVELOPMENT BLOCK GRANT FUNDS**

**CONTRACT - Part 1**

CONTRACT NO. \_\_\_\_\_

DATE OF AWARD \_\_\_\_\_

Distribution:

Original 1 - Clerk

Original 2 - Owner

Copy - Department of Development

PROPERTY DESCRIPTION: 2105 S. 68 St. and 6801-6807 W. Becher St.

TAX KEY NUMBER: 476-0154-000

IMPROVEMENTS (General): See attached Exhibit A – “Budget”, Exhibit B - “General Contractor Proposal”,  
Exhibit C – “Approved Architectural Plans” and Exhibit D – Federal Contract Provisions

TIME OF PERFORMANCE: December 31, 2015

TOTAL AMOUNT OF CONTRACT: Not to exceed \$20,000

THIS AGREEMENT, entered into by and between Lutz Land Management, LLC, Owner of 2105 S. 68 St. and 6801-6807 W. Becher St., hereinafter referred to as the "OWNER"), and the City of West Allis, a municipal corporation of the State of Wisconsin (hereinafter referred to as the "CITY").

Performance and schedules will be approved by John F. Stibal, Director, Department of Development (or his designee) of the City of West Allis, Department of Development.

Work may commence in accordance with approved performance and work schedules.

WITNESSETH THAT:

WHEREAS, The OWNER represents itself as being capable and qualified to undertake and have installed those certain facade improvements, as hereinafter set forth, as are required in accomplishing fulfillment of the obligations under the terms and conditions of this Contract.

NOW, THEREFORE, the parties hereto do mutually agree as follows:

- I. FACADE IMPROVEMENTS AND REQUIREMENTS. The OWNER hereby agrees to make the facade improvements as hereinafter set forth, all in accordance with the terms and conditions of this Contract. OWNER agrees time is of the essence and will meet all deadlines, any schedules as herein set forth, and is required to:
  - A. Do, perform, and carry out in a satisfactory, timely, and proper manner, the facade improvements delineated in this Contract.
  - B. Comply with requirements listed with respect to reporting on progress of the services, additional approvals required, and other matters relating to the facade improvements.
  - C. Comply with time schedules and payment terms.

- D. Make no changes to the building facade without Department of Development approval for a period of five (5) years from and after completion of the facade improvements, except for maintenance and changes to sign fascia for new tenants.
- E. The contract is funded with federal CDBG funds requiring the owner to fully comply with the statutes, laws, rules, regulations and other requirements outlined under the Federal Labor Standards Provisions hereby incorporated and made part of this contract as Exhibit A. Further, Exhibit A must be made part of any contract for work to be performed under a contract by and between the owner and contractor.
- F. Since the project is funded in part with federal Community Development Block Grant (CDBG) funds, work performed will require the payment of prevailing wage in accordance with the attached Wage Decision dated June 26, 2015, hereby incorporated and made a part of this contract as Exhibit D, Attachment #7. The owner is responsible for incorporating the wage decision into the contract for work to be performed under a contract by and between the owner and contractor.

II. SCOPE OF SERVICES. The OWNER shall in a satisfactory, timely and proper manner, undertake and complete the following project(s) as set forth in the attached Exhibit(s). Any Budget Amendment or Activity Report Amendment to be considered by the CITY from the OWNER must be submitted no later than ninety (90) days prior to the expiration of this Contract.

III. AVAILABILITY OF FUNDS.

- A. This contract award is 100% funded under the Federal Community Development Block Grant Program. Thus, should the availability of federal funds be reduced, the CITY and the OWNER agree that the City of West Allis, Department of Development can modify and reduce either the OWNER's compensation (as listed on Page 1 as the "Total Amount of Contract") or the OWNER's program year or both. (The Department of Development will notify the OWNER of such reduction).
- B. In the event of such modification or reduction, the parties shall agree upon the portions of the contract to be reduced or modified.

IV. NOTICES. Any and all notices shall be in writing and deemed served upon depositing same with the United States Postal Services as "Certified Mail, Return Receipt Requested,"

addressed to the OWNER at:

Lutz Land Management, LLC  
2105 S. 68 St.  
West Allis, WI 53219

and to the CITY at:

John F. Stibal, Director  
Department of Development  
City of West Allis  
7525 West Greenfield Avenue  
West Allis, Wisconsin 53214

All other correspondence shall be addressed as above, but may be sent "Regular Mail" and deemed delivered upon receipt by the addressee.

V. TIME OF PERFORMANCE. The facade improvements to be made under the terms and conditions of this Contract shall be in force and shall commence from approval of performance and work schedules by the Director of Development, and shall be undertaken and completed in such sequence as to assure its expeditious completion in the light of the purposes of this Contract, but in any event all of the services required hereunder shall be completed as indicated on Page 1 under "Time of Performance", which is the termination date of this Contract. In addition to all other remedies incurring to the CITY should the Contract not be completed by the date specified in accordance with all of its terms, requirements and conditions therein set forth, the OWNER shall continue to be obligated thereafter to fulfill OWNER's responsibility to amend, modify, change, correct or expand thereon until the Contract is fully completed.

VI. CONDITIONS OF PERFORMANCE AND COMPENSATION.

- A. Performance. The OWNER agrees that the performance of work, services and the results therefore, pursuant to the terms, conditions and agreements of this Contract, shall conform to such recognized high professional standards as are prevalent in this field of endeavor and like services.
- B. Place of Performance. The OWNER shall make the facade improvements to the following property:  
2105 S. 68 St. and 6801-6807 W. Becher St  
West Allis, WI 53214
- C. Compensation. The CITY agrees to reimburse the OWNER, subject to satisfactory completion and acceptance of the facade improvements by the Department of Development and the other contingencies herein, and the OWNER agrees to accept for the satisfactory completion of the facade improvements under this Contract an amount not to exceed the maximum as indicated on Page 1 under "Total Amount of Contract", inclusive of all expenses, it being expressly understood and agreed that in no event will the total compensation to be paid hereunder exceed said maximum sum for all of the required improvements. OWNER shall submit such invoices, statements, checks and other evidence of payment as the Department may require to verify the amount of reimbursement due under this Contract.
- D. Taxes, Social Security, and Government Reporting. Personal income tax payments, social security contributions, insurance and all other governmental reporting and contributions required as a consequence of the OWNER receiving payment under this Contract shall be the sole responsibility of the OWNER.
- E. The contract also incorporates Exhibit A Federal Labor Standards Provisions and Exhibit B General Wage Decision.

Approved as to form this \_\_\_\_\_ day  
of \_\_\_\_\_, 2015.

\_\_\_\_\_  
Jeffrey J. Warchol, Assistant City Attorney

(Signatures on the following page)

**CITY OF WEST ALLIS**

**Lutz Land Management, LLC**

By: \_\_\_\_\_  
John F. Stibal, Director  
Director of Development

By: \_\_\_\_\_

Date: \_\_\_\_\_

Date: \_\_\_\_\_

**Countersigned:**

By: \_\_\_\_\_  
Mark D. Wyss  
Director of Finance/Comptroller/Treasurer

Date: \_\_\_\_\_

lecon dev\cf6800 W Becher St – Lutz Land Mgmt\gmj\7-15

**CITY OF WEST ALLIS  
DEPARTMENT OF DEVELOPMENT  
FACADE DEMONSTRATION PROJECT  
COMMUNITY DEVELOPMENT BLOCK GRANT FUNDS**

**CONTRACT - Part 2**

CONTRACT NO. \_\_\_\_\_

DATE OF AWARD \_\_\_\_\_

This CONTRACT is funded, in whole or in part, with Federal Community Development Block Grant Funds. The OWNER will fully comply with the following statutes, laws, rules, regulations and other requirements during the term of the CONTRACT.

I. Non-Discrimination.

A. Title VI of the Civil Rights Act of 1964 (Pub. L. 86-352), and implementing regulations issued at 24 CFR Part 1, which provide that no person in the United States shall, on the grounds of race, color or national origin, be excluded from participation in, denied the benefits of or otherwise subjected to discrimination under any program or activity for which the person receives federal financial assistance and will immediately take measures necessary to effectuate this assurance.

B. Section 109 of the Housing and Community Development Act of 1969, as amended, and the regulations issued at 24 CFR 570.601, which provide that no person in the United States shall, on the grounds of race, color, national origin or sex, be excluded from participation in, denied the benefits of or subject to discrimination under any program or activity funded in whole or in part with funds provided under 24 CFR Part 570.

C. Section 504 of the Rehabilitation Act of 1973, as amended (Pub. L. 93-112), and implementing regulations when published for effect. Section 504 provides that no qualified handicapped person shall, on the basis of handicap, be excluded from participation in, denied the benefits of or otherwise subjected to discrimination under any program or activity which received or benefits from federal financial assistance.

II. Equal Employment Opportunity. (All Projects exceeding \$10,000). Executive Order 11246, as amended by Executive Order 11375, and as supplemented in Department of Labor Regulations (41 CFR Part 60).

A. The OWNER will not, in carrying out the Project, discriminate against any employee because of race, color, religion, sex, handicap or national origin. It will take affirmative action to insure that applicants for employment are employed, and that employees are treated during employment without regard to their race, color, religion, sex, handicap or national origin. Such action shall include, but not be limited to, the following: employment, upgrading, demotion or transfer, recruitment or recruitment advertising, layoff or termination, rates of pay or other forms of compensation and selection for training, including apprenticeship. The Sub-recipient shall post in conspicuous places, available to employees and applicants for employment, notices to be provided by HUD setting forth the provisions of this non-discrimination clause.

B. The OWNER will, in all solicitations or advertisements for employees placed by or on its behalf, state that all qualified applicants will receive consideration for employment without regard to race, color, religion, sex, handicap or national origin.

C. The OWNER will incorporate the foregoing requirements of this section in all of its contracts for Project work, except contracts for standard commercial supplies or raw materials or contracts covered under 24 CFR Part 570 and will require all of its contracts for such work to incorporate such requirements in all subcontracts for work done with funds provided under 24 CFR Part 570.

III. Employment Opportunities For Low Income Residents. Section 3 of the Housing and Urban Development Act of 1968, as amended, and implementing regulations at 24 CFR Part 135, requiring that to the greatest extent feasible, opportunities for training and employment be given to lower income residents of the Project area and contracts for work in connection with the Project be awarded to eligible business concerns which are located in or owned in substantial part by persons residing in the area of the Project.

IV. Age Discrimination Prohibited. The Age Discrimination Act of 1975, as amended, (Pub. L. 94-135), and implementing regulations (when published for effect).

V. Drug-Free Work Place. Sub-recipient certifies that it will provide a drug-free work place and will otherwise comply with the Drug-Free Work Place Act of 1988, as amended, and the regulations promulgated thereunder.

VI. Federal Management and Budget Requirements and Procurement Standards.

A. The regulations, policies, guidelines and requirements of OMB Circular Nos. A-102, Revised, and A-87, as they relate to the acceptance and use of federal funds under 24 CFR Part 570.

B. All requirements imposed by HUD concerning special requirements of law, program requirements and other administrative requirements approved in accordance with OMB No. A-102, Revised.

C. OMB Circular A-110.

VII. Environmental Review. OWNER will cooperate with the City in carrying out the following:

A. Consents to assume the status of a responsible federal official for environmental review, decision making and action pursuant to the National Environmental Policy Act of 1969, and the other authorities listed in Part 58, insofar as the provisions of such act or other authorities apply to 24 CFR Part 570.

B. Is authorized and consents to accept the jurisdiction of the federal courts for the purpose of enforcement of this section.

VIII. Historic Preservation. OWNER will comply with the requirements for historic preservation, identification and review set forth in Section 106 of the National Historic Preservation Act of 1966 (16 U.S.C. 470), Executive Order 11593, and the Archeological and Historic Preservation Act of 1974 (16 U.S.C. 469a, et seq.), regulations of the Advisory Council on Historic Preservation at 36 CFR 801, and any other regulations promulgated pursuant to section 21 of the Housing and Community Development Act of 1974, as amended.

IX. Relocation. The relocation requirements of Title II and the acquisition requirements of Title III of the Uniform Relocation Assistance and Real Property Acquisition Policies Act of 1970, implementing regulations at 24 CFR Part 42, and the special provisions of section 570.457, concerning the relocation of residential tenants not covered by the Uniform Act.

X. Labor Standards. The labor standards requirements as set forth in section 570.605 and HUD regulations issued to implement such requirements.

XI. Flood Insurance. The flood insurance purchase requirements of section 102(a) or the Flood Disaster Protection Act of 1973 (Pub. L. 93-234).

XII. Facilities. The OWNER will insure that the facilities under its ownership, lease or supervision which shall be utilized in the accomplishment of the Project are not listed on the Environmental Protection Agency's (EPA) list of violating facilities, and that it will notify HUD of the receipt of any communication from the Director of the EPA Office of Federal Activities, indicating that a facility to be used in the Project is under consideration for listing by the EPA.

XIII. Davis-Bacon. The Project may be subject, in whole or in part, to Federal Fair Labor Standards provisions in accordance with the Davis-Bacon Act, as amended (40 U.S.C. section 276a-276a-5), and implementing regulations issued at 24 CFR 570.603; and, the OWNER will agree that any such work will be done in accordance with such laws and regulations.

XIV. Religious Entity. As a general rule, per CFR 24, Part 570.200(j)(3), CDBG funds may be used for eligible public services to be provided through a primarily religious entity, where the religious entity enters into an agreement with the recipient or sub-recipient from which the CDBG funds are derived that, in connection with the provision of such services:

- (i) It will not discriminate against any employee or applicant for employment on the basis of religion and will not limit employment or give preference in employment to persons on the basis of religion;
- (ii) It will not discriminate against any person applying for such public services on the basis of religion and will not limit such services or give preference to persons on the basis of religion;
- (iii) It will provide no religious instruction or counseling, conduct no religious worship or services, engage in to religious proselytizing, and exert no other religious influence in the provision of such public services.

XV. Fraud. The OWNER has not knowingly and willingly made or used a document or writing containing any false, fictitious or fraudulent statement or entry. it is provided in 18 U.S.C. 1001 that whoever does so within the jurisdiction of any department or agency of the United States shall be fined not more than Ten Thousand Dollars (\$10,000) or imprisoned for not more than five (5) years, or both.

XVI. Remedies for Noncompliance. In the event of OWNER's noncompliance with any of the provisions of these General Conditions, the City shall impose such sanctions as it may determine to be appropriate, including, but not limited to:

- A. Withholding of payment of funding under the Agreement until Sub-recipient complies; and/or
- B. Immediate cancellation, termination or suspension of the Agreement, in whole or in part.
- C. Other remedies that may be legally available.

XVII. Section 3 Clause. All Section 3 covered contracts shall include the following clause (referred to as the Section 3 clause):

A. The work to be performed under this contract is subject to the requirements of section 3 of the Housing and Urban Development Act of 1968, as amended, 12 U.S.C. 1701u (section 3). The purpose of section 3 is to ensure that employment and other economic opportunities generated by HUD assistance or HUD assisted projects covered by section 3, shall, to the greatest extent feasible, be directed to low- and very low-income persons, particularly persons who are recipients of HUD assistance for housing.

B. The parties to this contract agree to comply with HUD's regulations in 24 CFR part 135, which implement section 3. As evidenced by their execution of this contract, the parties to this contract certify that they are under no contractual or other impediment that would prevent them from complying with the part 135 regulations.

\_\_\_\_\_  
Owner Initials

\_\_\_\_\_  
City Representative Initials

hecon dev\c\6800 W Becher St - Lutz Land Mgmt\gmj\7-15

**Attached**

**Exhibit A**

**“Budget”**



6800 W. Becher St.  
Mark Lutz

Commercial Façade Grant

Item	Price/Budget	%	Owner	%	Grant Amount		
Permit Fees	\$ 500	50%	\$ 250	50%	\$ 0	\$ 500	
Masonry EFIS	\$ -	50%	\$ -	50%	\$ -	\$ -	
Siding	\$ -	50%	\$ -	50%	\$ -	\$ -	
Storefront windows	\$ 23,419	50%	\$ 11,710	50%	\$ 11,710	\$ 23,419	
Retuse Coral	\$ -	50%	\$ -	50%	\$ -	\$ -	
Entrance Door	\$ -	50%	\$ -	50%	\$ -	\$ -	
Electrical	\$ 4,285	50%	\$ 2,143	50%	\$ 2,143	\$ 4,285	
Lighting	\$ -	50%	\$ -	50%	\$ -	\$ -	
Garage Siding	\$ -	50%	\$ -	50%	\$ -	\$ -	
Tiles	\$ -	50%	\$ -	50%	\$ -	\$ -	
Parking Lot *	\$ -	50%	\$ -	50%	\$ -	\$ -	
Painting	\$ -	50%	\$ -	50%	\$ -	\$ -	
Awning	\$ 3,620	50%	\$ 1,810	50%	\$ 1,810	\$ 3,620	
Privacy Fence	\$ -	50%	\$ -	50%	\$ -	\$ -	
Rendering	\$ -	50%	\$ -	50%	\$ -	\$ -	
Architectural Services	\$ 3,000	50%	\$ 1,500	50%	\$ 1,500	\$ 3,000	
Plan Review	\$ 500	50%	\$ 250	50%	\$ 250	\$ 500	
Signs	\$ 2,000	50%	\$ 1,000	50%	\$ 1,000	\$ 2,000	
Revised Plans	\$ -	50%	\$ -	50%	\$ -	\$ -	
Landscaping	\$ -	50%	\$ -	50%	\$ -	\$ -	
Demo	\$ 3,000	50%	\$ 1,500	50%	\$ 1,500	\$ 3,000	
<b>TOTAL GRANT</b>	<b>\$ 40,324</b>		<b>\$ 20,162</b>		<b>\$ 20,162</b>	<b>\$ 40,324</b>	
Total Project Cost	\$ 40,324		\$ 20,162	50%			
Owner	\$ 20,162	50%					
City	\$ -	100%					

Spray-o-bond \$10,200.00  
Lumens 31070

3800

**Attached**

**Exhibit B**

**“General Contract Proposal”**



# AWNING & TENT CO., INC.

8768 West Fond du Lac Avenue • Milwaukee, WI 53225  
Phone (414) 463-7640 • Fax (414) 463-4447

July 10, 2015

Mark Lutz  
At: 6801 W. Becher Street  
Milwaukee, WI 53219

Dear Mr. Lutz,

We are pleased to quote the following concerning awning work for the above referenced property.

The approximate sizes and configurations of the awnings would be as per the attached sketch and digital photo rendering.

Frames for all awnings would be 3/4 inch square electro-plated steel tube, welded assembly, with all welds ground smooth and painted.

Fabric covers for all awnings would be "Sunbrella" Brand 100% acrylic fiber in the color of your choice. There are approximately 160 different colors/patterns to select from in this fabric. We have shown color #4667 Mahogany in the attached digital photo rendering and have enclosed a sample for your review.

Prices, including all framework and hardware, fabric covers in the color of your choice and installation by Igl Awning are as follows:

6' Wide (east)	.....	\$ 520.00	} \$3,620
12'9" Wide	.....	\$1020.00	
14'4" Wide	.....	\$1140.00	
18'3" Wide	.....	\$1460.00	

You can be assured of the finest quality workmanship and materials, and the most professional installation by Igl Awning.

Please allow 6 to 8 weeks for completion after placing an order.

We are pleased to issue this quotation and hope to be favored with your order.

Yours truly,  
Larry Dobraska  
Vice President

OF CANVAS

# AGL

YOU NAME IT - WE MAKE IT

## AWNING & TENT CO., INC.

8768 West Fond du Lac Avenue • Milwaukee, WI 53225

Phone (414) 463-7640 • Fax (414) 463-4447

PROPOSED AWNING FOR  
MARK LUTZ ARTS  
6801 W. BOCHER ST

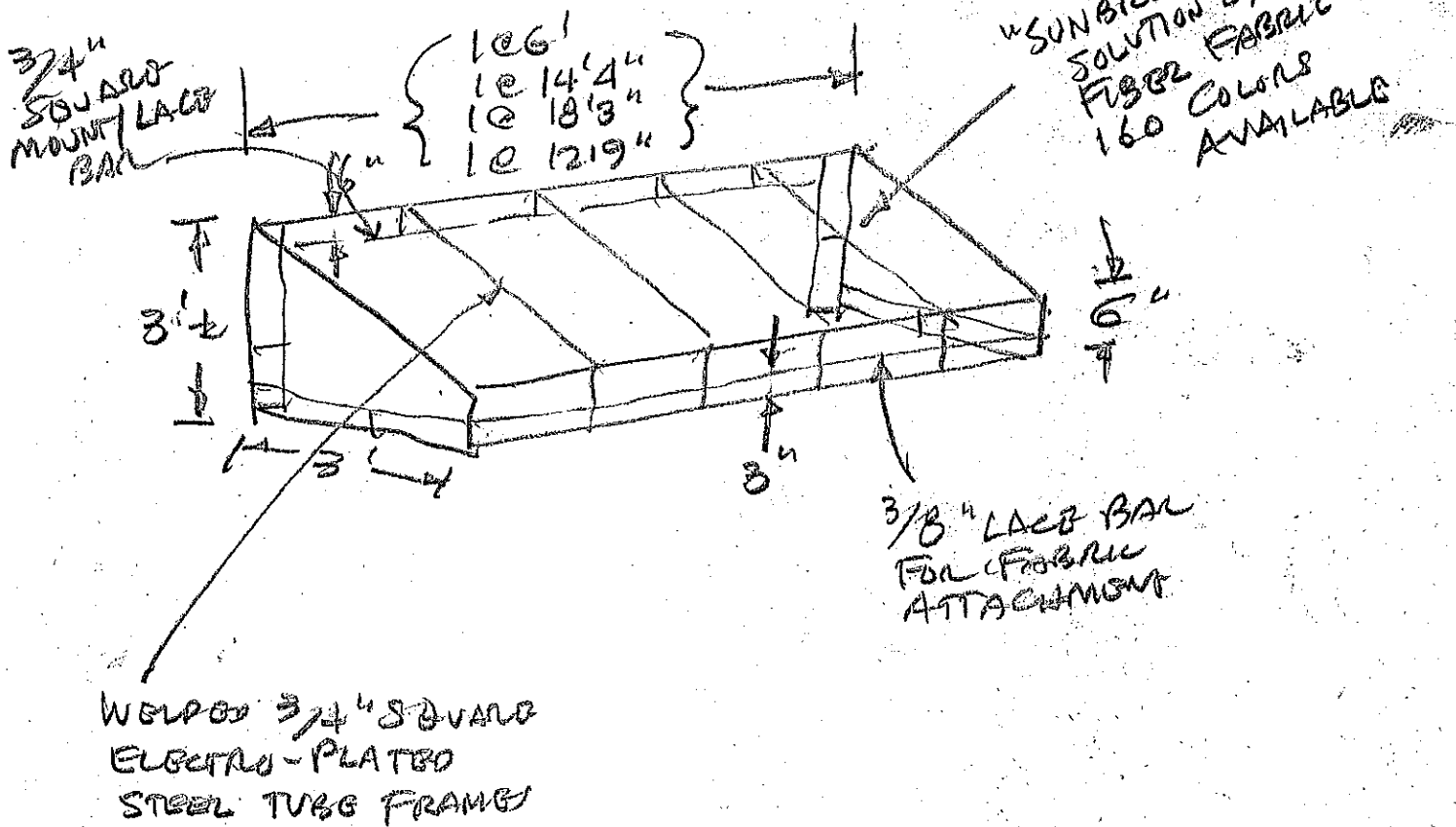

801 W. Becher Street



Three stationary shed style awnings in Sunbrella color #4667 Mahogany.

Friday, July 10, 2015  
IGL Trailer & Awning

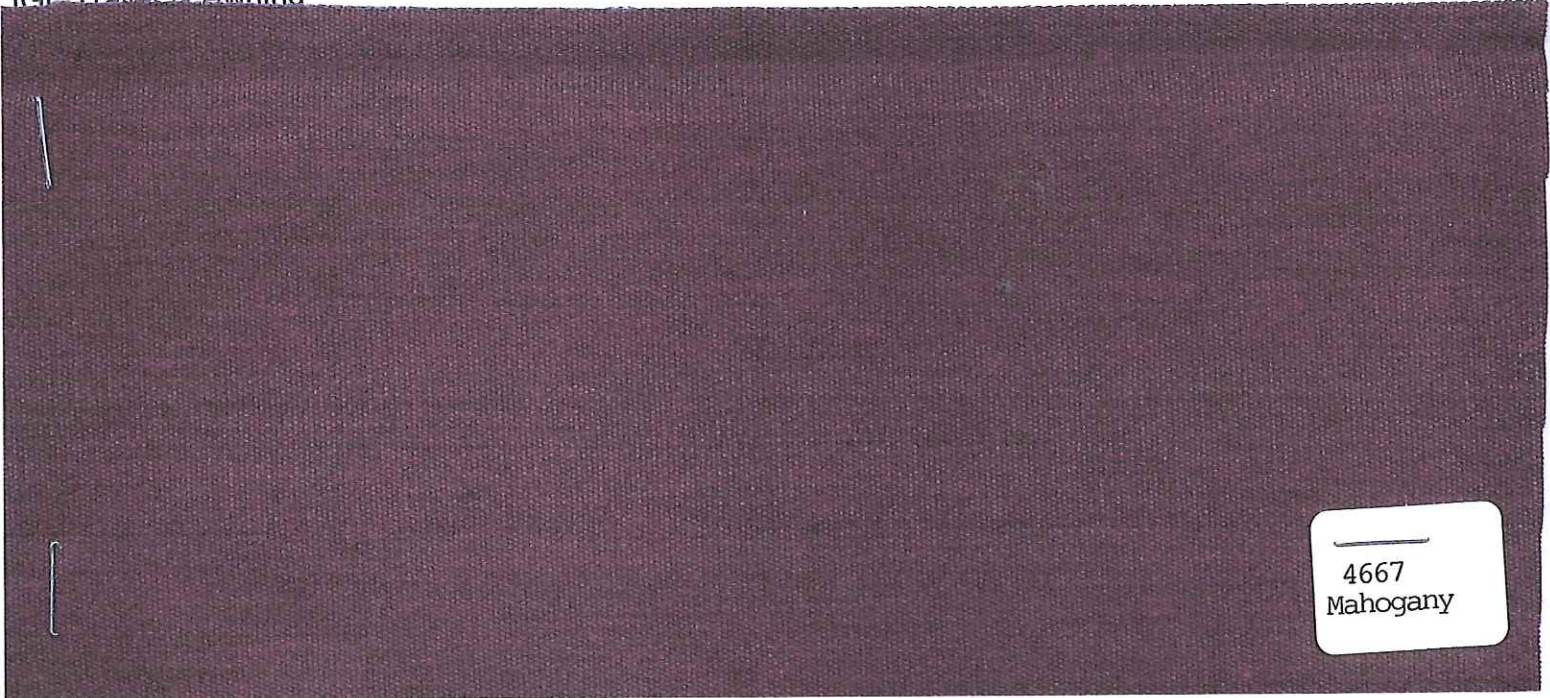

4667  
Mahogany

# BID PROPOSAL

DATE: July 14, 2015  
Project Name: 6801 W. Beecher St.  
Location: 6801 W. Beecher St.



ATTN: Mark Lutz  
To: Mark Lutz  
6832 W. Beecher St.  
West Allis, WI 53219

11233 W Greenfield Ave.  
West Allis, WI 53214  
414-771-5660  
Fax 414-771-7924

## We propose to furnish and install:

- FRAMING:** The framing for the storefront will be Kawneer 451T center glazed framing system.
- DOORS:** The two 36" x 84" doors will be Kawneer 350 medium stile with 10" bottom rails and standard door hardware.
- HARDWARE:** The standard door hardware consists of an Adamsrite MS1850 dead bolt lock with a cylinder and thumb turn, push/pull, and 1 1/2 pair of butt hinges. The two doors will be furnished with Dorma surface mounted closers and bottom door sweeps.
- GLASS:** The glass for the storefront and doors will be 1" clear Low E. The glass will be tempered per code.
- FINISH:** The finish of the framing and the doors will be bronze anodized.
- CLARIFICATIONS:** **This price includes brake metal column covers and sill flashing.**
- EXCLUSIONS:**
- 1) Final cleaning is excluded. We will remove labels and excess sealants from framing and glass surfaces at time of installation.
  - 2) Glass is not warranted against breakage. We will replace broken glass caused directly by our employees at time of installation.
  - 3) Furnishing of temporary enclosures, temporary material protection and removal or resetting of temporary enclosures is excluded.
  - 4) Customer to provide solid anchoring at perimeter conditions to withstand loads.

**FOR THE SUM OF** Twenty three thousand four hundred and nine dollars **\$23,419**

**ALTERNATES:**

**THIS PROPSAL IS SUBJECT TO THE FOLLOWING TERMS & CONDITIONS:**

- 1) Proposal is subject to revision if not accepted in writing within 30 days.
- 2) Proposal, if accepted, is subject to approval by the Credit Department of Milwaukee Plate Glass. Terms of payment are NET 30 unless other terms are negotiated. Milwaukee Plate Glass does not accept the risk of Customer's receipt of payments from any source, and in no event will payments to MPG be based upon, or subject to, Customer's receipt of payment for MPG's work. Subcontractor does not accept the risk of Customer's receipt of payments from any source, and in no event will payments to Subcontractor be based upon, or subject to, Customer's receipt of payment for Subcontractor's work.
- 3) No back charge or claim of Customer for services shall be valid except by an agreement in writing by Subcontractor before the work is executed. In such event, Customer shall notify Subcontractor of such default, in writing, and allow Subcontractor reasonable time to correct any deficiency before incurring any costs chargeable to Subcontractor.
- 4) Subcontractor shall be entitled to equitable adjustments of the contract price. Including but not limited to any increased costs of labor, supervision, equipment or materials, and reasonable overhead and profit, for any modification of the project schedule differing from the bid schedule, and for any other delays, acceleration, out-of-sequence work and schedule changes beyond Subcontractor's reasonable control, including but not limited to those caused by labor unrest, fires, floods, acts of nature or government, wars, embargos, vendor priorities and allocations, transportation delays, suspension of work for non-payment or as ordered by Customer, or other delays caused by Customer or others. Should work be delayed by any of the aforementioned causes for a period exceeding ninety (90) days, Subcontractor shall be entitled to terminate the subcontract. Subcontractor change proposals must be processed in not more than 30 calendar days or as otherwise indicated on the change proposal.
- 5) Subcontractor shall be entitled to equitable adjustments of the contract time for extra work it performs in accordance with the subcontract documents, and for extra work it performs pursuant to written or verbal instructions of Customer, provided that Subcontractor gives Customer notice prior to starting such extra work, identifying the date and source of the instructions considered as requesting extra work. Subcontractor shall also be entitled to payment for said extra work. Subcontractor may also claim damages for cumulative impact of multiple changes on Subcontractor's efficiency. Subcontractor's entitlement to adjustments shall not be contingent upon, or limited to, adjustments received by Customer.
- 6) Except as specifically required in subcontractor's scope of work, Customer shall furnish all temporary site facilities, including but not limited to site access, storage space, hoisting facilities, guard rails, covers for floor, roof and wall openings, security, parking, safety orientation, break and lunch facilities, toilet and wash facilities, drinking water and other water facilities, electrical service, telecommunication service, lighting, heat, ventilation, weather protection, fire protection, and trash and recycling services.
- 7) Any indemnification or hold harmless obligation of Subcontractor extends only claims relating to bodily injury and property damage (other than to the subcontractor's work), and then only to that part or proportion of any claim caused by the negligence or intentional act of Subcontractor, its sub-subcontractors, their employees, or others for whose acts they may be liable. Subcontractor shall not have a duty to defend. This paragraph does not, however, restrict obligations of Subcontractor, if any, to indemnify Customer against intellectual property infringement claims or against claims for payment for work for which Subcontractor has been paid.
- 8) Subcontractor's work shall be executed in substantial compliance with the Subcontract Documents, in a good and workmanlike manner, and free of defect not inherent in the design or specified materials. This warranty excludes any remedy for damages or defects caused by ordinary wear and rear, and agrees that Subcontractor does not warrant the adequacy, sufficiency, suitability or building code compliance of the plans, specifications, or other Contract Documents including, without limitation, any specified sole source of brand-name products, equipment, or materials, and Customer accepts the manufacturer's warranty as its sole recourse with regard to such items. **THIS WARRANTY IS PROVIDED IN LIEU OF ALL OTHER WARRANTIES, EXPRESS OR IMPLIED, AND THE WARRANTIES OF MERCHANTABILITY AND FITNESS FOR A PARTICULAR PURPOSE ARE HEREBY DISCLAIMED BY SUBCONTRACTOR.** Subcontractor is not responsible for special, incidental, or consequential damages, Subcontractor is not responsible for damage to its work by other parties, and any repair work necessitated by such damage is extra work. Subcontractor's responsibility for damage or loss in transit ceases upon delivery in good condition to a public carrier. All materials shall be furnished in accordance with the respective industry tolerance of color variation, thickness, size, finish, texture and performance standards. All warranty claims must be received by Subcontractor in writing not more than one (1) year after completion of subcontractor's work, and Subcontractor must be provided a reasonable opportunity to inspect and make corrections, or such warranty claims are barred.

ACCEPTED: \_\_\_\_\_

YOURS TRULY,

MILWAUKEE PLATE GLASS COMPANY

DATE: \_\_\_\_\_

Rick Sjostrom

July 14, 2015

Mark Lutz  
6832 W. Becher St  
West Allis, WI. 53219  
mlutz12368@gmail.com

Re: 6801 W. Becher St

We propose to provide all labor, materials and permit to complete the following detailed scope of work.

**SCOPE OF WORK: Upgrade both esthetic and security lighting of exterior of building.**

- To west elevation, add (2) E-conolight Premium LED Wall Packs, Model #E-WP6LO3NZ. This fixture is comparable to a 100 watt high pressure sodium, also providing maximum control of spill light.
- To the north elevation, add (4) Straight Shroud, LED Gooseneck fixtures, Model #E-DG1L13USK. This fixture is comparable to a 100 watt incandescent, providing accent illumination to architectural design.
- To the two entrance signs, add (2) Premium LED Directional Spotlights at each entrance, Model#E-GL4SO3N2K.
- To control all exterior lighting fixture, add (1) simple Intermatic 24-Hour, 7-Day mechanical time clock Model#T101

This design is done with advanced LED technology; therefore, reducing energy use and maintenance costs, both important in any City of West Allis requirements. This is an elegant light source, ideal for business storefronts, making it a smart upgrade choice at only a slight increase in fixture cost from incandescent.

**The contract sum to complete this work is \$4,285.00**

**PAYMENT TERMS**

**Payment is due net 20 days upon completion of the above work. A 3.5% charge will be added for debit or credit card payments.**

**OTHER TERMS**

The Contract Sum identified above is valid for sixty (60) days after this Contract is signed by Best Electric Service, Inc.



By signing and returning this Contract, Customer confirms receipt of this Contract, the Notice of Lien Rights and Notice of Right to cancel, acknowledges approval of the terms of this Contract and authorizes BES to proceed with its work.

Any extra work required by Customer shall be performed after the Customer signs a written change order. Corrections for any existing code violations not specified in this contract are the responsibility of the owner. Hidden structural impairments to work or hidden damaged wiring not listed in this contract will be presented to owner and may create additional charges. This contract does not include any electric utility charges.

Customer supplied materials must meet NEC standards in order to be installed.

The customer agrees to provide a clean and safe work environment before work begins. Customer agrees to provide and maintain a 30" wide by 36" deep working area in front of the circuit breaker panel if Best Electric will be accessing this panel for any reason.

There is a \$35.00 charge if Customer's check or charge card transaction is returned for any reason or cancelled after conveyed to BES. A service charge of 1.5% per month, compounded monthly, will be added to any past due amount.

The Notice of Lien Rights and Notice of Right to cancel are hereby incorporated by reference into this contract and any subsequent change orders. If this Contract is cancelled at any time later than the third day after it has been signed by Customer, Customer shall pay \$100.00 to BES to cover preparation and permit costs, plus all costs of work performed and costs of materials purchased to date of cancellation.

Any disputes arising out of this Contract shall be resolved via arbitration before the local chapter of NARI pursuant to its rules, and Wisconsin law shall apply to interpretation of the Contract. All costs of collection, including reasonable attorney fees, shall be paid by Customer. If Customer is unable to pay a judgment issued for collection of amounts due under this Contract, BES reserves the right, with assistance of law enforcement officials, to remove any materials or equipment installed at Customer's premises.

#### NOTICE OF LIEN RIGHTS

**AS REQUIRED BY WISCONSIN CONSTRUCTION LIEN LAW, BEST ELECTRIC SERVICE, INC. HEREBY NOTIFIES THE CUSTOMER THAT PERSONS OR COMPANIES FURNISHING LABOR AND/OR MATERIALS FOR THE CONSTRUCTION ON CUSTOMER'S PROPERTY MAY HAVE LIEN RIGHTS IF NOT PAID. THOSE ENTITLED TO LIEN RIGHTS, IN ADDITION TO BEST ELECTRIC SERVICE, INC., ARE THOSE WHO CONTRACT DIRECTLY WITH THE CUSTOMER OR THOSE WHO GIVE THE CUSTOMER NOTICE WITHIN SIXTY (60) DAYS AFTER THEY FIRST FURNISH LABOR AND/OR MATERIALS FOR CONSTRUCTION. ACCORDINGLY, THE CUSTOMER PROBABLY WILL RECEIVE NOTICES FROM THOSE WHO FURNISH LABOR AND/OR MATERIALS FOR THE CONSTRUCTION, AND SHOULD GIVE A COPY OF EACH NOTICE TO THEIR LENDER, IF ANY. BEST ELECTRIC SERVICE, INC. AGREES TO COOPERATE WITH THE CUSTOMER AND THEIR LENDER TO SEE THAT ALL POTENTIAL LIEN CLAIMANTS ARE DULY PAID.**

 Date: 07/14/2015  
Paul Armstrong, Pres., Best Electric Service, Inc

Accepted:

\_\_\_\_\_  
Owner Date: \_\_\_\_\_

Attached

Exhibit C

**“Approved Architectural Plans”**



8806 GEOI W BECKER ST FACADE REMODEL  
WEST ALLIS WI





**Attached**

**Exhibit D**

**“Federal Contract Provisions”**

# FEDERAL CONSTRUCTION CONTRACT PROVISIONS

Community Development Block Grant Program



Community Development Division

City of West Allis

7525 W. Greenfield Avenue

West Allis, WI 53214

(414) 302-8460

## **SECTION 1 INTRODUCTION**

- 1. Minority Business Participation**
- 2. Code of Conduct**
- 3. Record Retention**
- 4. Contract Provisions**
- 5. Certification Regarding Use of Contract Funds for Lobbying**
- 6. Access to Records**

## **SECTION 2 EQUAL EMPLOYMENT OPPORTUNITY REGULATIONS**

- 1. Equal Opportunity**
- 2. EEO Officer**
- 3. Dissemination of EEO Policy**
- 4. Recruitment of Employees**
- 5. Selection of SubCONTRACTORS, Procurement of Materials and Leasing of Equipment**
- 6. EEO Records and Reports**
- 7. Nonsegregated Facilities**
- 8. Falsification of Documents**
- 9. Section 3 Clause and Requirements**
- 10. Office of Federal Contract Compliance Programs (OFCCP)**

## **SECTION 3 FEDERAL LABOR STANDARDS REGULATIONS**

- 1. Regulations**
- 2. Certification Regarding Debarment, Suspension, Ineligibility and Voluntary Exclusion**
- 3. Instructions for Certification Lower Tier Covered Transactions**
- 4. Payment of Prevailing Wages**
- 5. Personnel Actions**
- 6. Conformance Rates**
- 7. Payment of Fringe Benefits**
- 8. Apprentice Participation**
- 9. Overtime Requirements**
- 10. Withholding Payments**
- 11. Violations and Liability**
- 12. Statements and Payrolls**

## **SECTION 4 HEALTH & SAFETY**

- 1. Safety and Accident Prevention**
- 2. Implementation of Clean Air Act and Federal Water Pollution Control Act**

## **SECTION 5 ATTACHMENTS**

- 1. Minority and Women's Business Goals**
- 2. Minority and Women's Business Compliance Report**
- 3. Federal Labor Provisions- HUD FORM 4010**
- 4. Equal Employment Opportunity Poster**
- 5. Economic Opportunities for Low and Very Low Income Persons**
- 6. Notice to All Employees of Federally Assisted Projects**
- 7. Wage Decision**
- 8. Prevailing Wage Payroll Format**
- 9. Health and Safety Poster**



## **1. MINORITY BUSINESS PARTICIPATION:**

On each CDBG funded project, the CONTRACTOR is required to maintain documentation supporting their best efforts to achieve the HUD goal of MBE/WBE participation. Only those businesses duly registered on Wisconsin Department of Commerce Minority and Women's Business Directory may be counted toward the goal. The directory is available at [www.commerce.state.wi.us/php/mbe-od/alpha\\_result\\_page.php](http://www.commerce.state.wi.us/php/mbe-od/alpha_result_page.php) or [http://commerce.wi.gov/php/WBE/wbe\\_od\\_start.php/name](http://commerce.wi.gov/php/WBE/wbe_od_start.php/name).

The goals are provided under **Section 5 -- Attachment 1**.

The CONTRACTOR will take all necessary affirmative steps to assure that minority firms, women's business enterprises, and labor surplus area firms are used when possible (24 CFR Part 85.36(e)).

Affirmative steps shall include:

- A. Placing qualified small and minority businesses and women's business enterprises on solicitation lists;
- B. Assuring that small and minority businesses and women's business enterprises are solicited whenever there are potential sources;
- C. Dividing total requirements, when economically feasible, into smaller tasks or quantities to permit maximum participation by small and minority businesses and women's business enterprises;
- D. Establishing delivery schedules, where the requirement permits, which encourage participation of small and minority businesses and women's business enterprises;
- E. Using the services and assistance of the Small Business Administration, and the Wisconsin Department of Commerce; and
- F. Requiring the prime CONTRACTOR, if subcontracts are to be let, to take the affirmative steps stated above A-E.

**The reporting charts under Section 5- Item 2 will require completion to document minority firms and women enterprises were provided the opportunity to bid or provide services under this Contract bid.**

## **2. CODE OF CONDUCT: 24 CFR 84.42**

The contract utilizing all or part grant funds shall maintain written standards of conduct governing the performance of employees engaged in the award and administration of contracts stating that no employee, officer, or agent shall participate in the selection, award, or administration of a contract supported by Federal funds if a real or apparent conflict of interest would be involved.

## **3. RECORD RETENTION: 24 CFR 85.42**

Financial records, supporting documents, statistical records and all other records pertinent to a grant shall be retained for a period of five years. If any litigation, claim, negotiation, audit or other action is started before the expiration of the five-year period, the records shall be retained until all litigations, claims or audit findings involving the records have been resolved. The retention period starts from the date of the submission of the final expenditure report or, from the date of the submission of the annual financial status report covering the last expenditure of grant funds for that year.

## **4. CONTRACT PROVISIONS:**

In addition to provisions defining a sound and completed procurement contract, the CONTRACTOR must adhere to **Federal Labor Provisions- HUD FORM 4010 under Section 5 -- Attachment 3**.

***Required Contract Provisions Federally Assisted Construction Contracts:***

Contracts other than small purchases shall contain provisions or conditions, which will allow for administrative, contractual, or legal remedies in instances where CONTRACTORS violate or breach contract terms, and provide for such sanctions and penalties as may be appropriate.

If this contract is in excess of \$25,000, the contract provides provision for termination including the manner by which it will be effected and the basis for settlement. In addition, such contract shall describe conditions under which the contract may be terminated for default as well as conditions where the contract may be terminated because of circumstances beyond the control of the CONTRACTOR.

If the contract is in excess of \$100,000, the contract requires compliance with all applicable standards, orders, or requirements issued under Section 306 of the Clean Air Act (42 USC 1857 (h)), Section 508 of the Clear Water Act (33 USC 1368), Executive Order 11738, and Environmental Protection Agency regulations (40 CFR, Part 15), which prohibit the use under non-exempt federal contracts, grants or loans of facilities included on the EPA List of Violating Facilities. The provision shall require reporting of violations to the City, HUD and to the US EPA Administrator for Enforcement (EN-329).

These contract provisions shall apply to all work performed on the contract by the CONTRACTOR's own organization and with the assistance of workers under the CONTRACTOR's immediate superintendence and to all work performed on the contract.

Except as otherwise provided for in each section, the CONTRACTOR shall insert in each subcontract all of the stipulations contained in these Required Contract Provisions, and further require their inclusion in any lower tier subcontract that may in turn be made. The prime CONTRACTOR shall be responsible for compliance by any subCONTRACTOR or lower tier subCONTRACTOR with these Required Contract Provisions.

A breach of any of the stipulations contained in these Required Contract Provisions shall be sufficient grounds for termination of the contract.

A breach of the Required Contract Provisions may also be grounds for debarment as provided in 29 CFR 5.12.

**5. CERTIFICATION REGARDING USE OF CONTRACT FUNDS FOR LOBBYING:**

(Applicable to all Federal-aid construction contracts and to all related subcontracts, which exceed \$100,000 -- 49 CFR 20)

The CONTRACTOR certifies, by signing and submitting this bid or proposal, to the best of his or her knowledge and belief that:

No Federal appropriated funds have been paid or will be paid, by or on behalf of the undersigned, to any person for influencing or attempting to influence an officer or employee of any Federal agency, a Member of Congress, an officer or employee of Congress, or an employee of a Member of Congress in connection with the awarding of any Federal contract, the making of any Federal grant, the making of any Federal loan, the entering into of any cooperative agreement, and the extension, continuation, renewal, amendment, or modification of any Federal contract, grant, loan, or cooperative agreement.

If any funds other than Federal appropriated funds have been paid or will be paid to any person for influencing or attempting to influence an officer or employee of any Federal agency, a Member of Congress, an officer or employee of Congress, or an employee of a Member of Congress in connection with this Federal contract, grant, loan, or cooperative agreement, the undersigned shall complete and submit Standard Form-LLL, "Disclosure Form to Report Lobbying", in accordance with its instructions.

This certification is a material representation of fact upon which reliance was placed with this transaction was made or entered into. Submission of this certification is a prerequisite for making or entering into this transaction imposed by 31 U.S.C. 1352. Any person who fails to file the required certification shall be subject to a civil penalty of not less than \$10,000 and not more than \$100,000 for each such failure.

The prospective participant also agrees that by submitting a bid or proposal that they require that the language of this certification be included in all lower tier subcontracts, which exceed \$100,000, and that all such recipients shall certify and disclose accordingly.

Any and all CONTRACTORS, subCONTRACTORS, independent CONTRACTORS, suppliers, facilitators or any person participating in any program or activity receiving federal financial assistance shall:

- a. Prohibit discrimination based on race, color or national origin under Title VI of the Civil Rights Act of 1964;
- b. Prohibit discrimination on the basis of sex under Title VII of the Civil Rights Act of 1964 and amended by the Equal Employment Opportunity Act of 1972;
- c. Prohibit discrimination on the basis of age under the Age Discrimination Act of 1975;
- d. Prohibit discrimination on the basis of disability under Section 504 of the Rehabilitation Act of 1973;
- e. Take affirmative action to employ and advance qualified disabled people under Section 503 of the Rehabilitation Act of 1973;
- f. Promote and insure equal opportunity for all persons, without regard to race, color, religion, sex, or national origin under Executive Order 11246 as Amended;
- g. Display posters, which summarize the Federal laws prohibiting job discrimination based on race, color, sex, national origin, religion, age, equal pay and disability;
- h. Prohibit discrimination based on disability under the Americans with Disabilities Act of 1990;
- i. Assure that all buildings assigned for public use be designed, constructed and altered so as to be accessible to and usable by persons with physical disabilities under the Architectural Barriers Act of 1968; and
- j. Avoid maintaining or providing any segregated facilities.

Any and all CONTRACTORS, subCONTRACTORS, independent CONTRACTORS, suppliers, facilitators or any person participating in any program or activity receiving federal financial assistance shall:

Comply with the provisions for the elimination of Lead-Based paint hazards under 24 CFR Part 35;

Take all necessary precautions to guard against damages to property and injury to persons.

#### **6. ACCESS TO RECORDS: 24 CFR 85.42-e**

The awarding agency and the Comptroller General of the United States, or any of their authorized representatives, shall have the right of access the CONTRACTOR's pertinent books, documents, papers or other records which are pertinent to the grant and/or project in order to make audits, examinations, excerpts and transcripts. The right of access in this section must not be limited to the required retention period but shall last as long as the records are retained.

### **SECTION 2 Equal Employment Opportunity Regulations**

#### **1. Equal Employment Opportunity Regulations**

Since this project will be financed all or in part with Community Development Block Grant funds, the CONTRACTOR and any subcontractors shall be required to meet all regulations of the Federal Government and the HUD in regard to equal opportunity and employment practices. The award of this contract will not be made until the successful bidder has demonstrated ability to comply with all these regulations as required by the HUD.

The apparent low bidder will be required to show compliance with federal regulations. **See Equal Employment Opportunity Poster under Section 5- Attachment 5 for required posting at all work sites.**

(Applicable to all Federal-aid construction contracts and to all related subcontracts of \$10,000 or more)

The CONTRACTOR will include the portion of the following provisions of Paragraphs A through H in every subcontract or purchase order unless exempted by rules, regulations or orders of the Secretary of Labor issued pursuant to Section 204 of Executive Order 11246 of September 24, 1965, as amended by Executive Orders 11375 and 13279, as supplemented in Department of Labor regulations (41 CFR Part 60), so that such provisions will be binding upon each subcontract or purchase order as the CITY may direct as a means of enforcing such provisions, including sanctions for noncompliance; provided, however, that in the event the CONTRACTOR becomes involved in, or is threatened with litigation with a subcontractor or vendor as a result of such direction by the CITY, the CONTRACTOR may request the United States to enter into such litigation to protect the interest of the United States.

Equal employment opportunity (EEO) requirements are not to discriminate and to take affirmative action to assure equal opportunity as set forth under laws, executive orders, rules, regulations (28 CFR 35, 29 CFR 1630 and 41 CFR 60) and orders of the Secretary of Labor as modified by the provisions prescribed herein, and imposed pursuant to 23 U.S.C. 140 shall constitute the EEO and specific affirmative action standards for the CONTRACTOR's project activities under this contract. The Equal Opportunity Construction CONTRACTOR Specifications set forth under 41 CFR 60-4.3 and the provisions of the American Disabilities Act of 1990 (42 U.S.D. 12101 et seq.) set forth under 28 CFR 35 and 29 CFR 1630 are incorporated by reference in this contract. In the execution of this contract, the CONTRACTOR agrees to comply with the following minimum specific requirement activities of EEO.

The CONTRACTOR will work with the awarding agency and the Federal Government in carrying out EEO obligations and in their review of his/her activities under the contract.

- A. The CONTRACTOR will not discriminate against any employee or applicant for employment because of race, color, religion, sex orientation, sex, age or national origin. The CONTRACTOR will take affirmative action to ensure that applicants are employed and that employees are treated during employment without regard to their race, color, sex orientation, religion, sex or national origin. Such action shall include, but not be limited to the following: Employment, upgrading, demotion or transfer, recruitment or recruitment advertising, layoff or termination, rates of pay or other forms of compensation and selection for training, including apprenticeship. The CONTRACTOR agrees to pose in conspicuous places available to employees and applicants for employment, notices to be provided by the contracting officer setting forth the provisions of this nondiscrimination clause.
- B. The CONTRACTOR will, in all solicitations or advertisements for employees placed by or on behalf of the CONTRACTOR, state that all qualified applicants will receive consideration for employment without regard to race, color, sex orientation, religion, sex, age, or national origin.
- C. The CONTRACTOR will send to each labor union or representative of workers with which a collective bargaining agreement or other contract or understanding, a notice to be provided by the Contract Officer advising that said labor union or workers' representatives of CONTRACTOR'S commitment under this section, and shall post copies of the notice in conspicuous places available to employees and applicants for employment.
- D. The CONTRACTOR will comply with all provisions of Executive Order 11246 of September 24, 1965, as amended by Executive Order 13279 dated December 12, 2002, and of the rules, regulations, and relevant orders of the Secretary of Labor.
- E. The CONTRACTOR will furnish all information and reports required by Executive Order 11246 of September 24, 1965, as amended by Executive Order 13279, and by the rules, regulations and orders of the Secretary of Labor, or pursuant thereto, and will permit access to its books, records and accounts by the City

and Secretary of Labor for purposes of investigation to ascertain compliance with such rules, regulations, and orders.

- F. In the event of the CONTRACTOR's noncompliance with the non-discrimination clause of this Contract or with any of such rules, regulations or orders, this Contract may be canceled, terminated or suspended in whole or in part and the CONTRACTOR may be declared ineligible for further government contracts or federally assisted construction contract procedures authorized in Executive Order 13279 or by rule, regulation or order of the Secretary of Labor, or as otherwise provided by law.
- G. The CONTRACTOR will include provisions of Paragraph A through H in every subcontract or purchase order unless exempted by rules, regulations or orders of the Secretary of Labor issued pursuant to Section 204 of Executive Order 11246 of September 24, 1965, so that such provisions will be binding upon each subcontractor or vendor. The CONTRACTOR will take such action with respect to any subcontract or purchase order as the CITY may direct as a means of enforcing such provision, including sanctions for noncompliance; provided, however, that in the event the CONTRACTOR becomes involved in, or is threatened with litigation with a subcontractor or vendor as a result of such direction by the CITY, the CONTRACTOR may request the United States to enter into such litigation to protect the interest of the United States.
- H. No person in the United States shall, on the ground race, color, sex orientation, religion, sex, age, or national origin be excluded from participation in, be denied the benefits of, or be subject to discrimination under any program or activity made possible by or resulting from this Contract. The CITY and each employer will comply with all requirements imposed by or pursuant to the regulations of the appropriate federal agency effectuating Title VI of the Civil Rights Act of 1964.

## **2. CONTRACTOR EEO OFFICER:**

The CONTRACTOR will designate and make known to the City of West Allis the EEO Officer who will have the responsibility for and must be capable of effectively administering and promoting an active CONTRACTOR program of EEO and who must be assigned adequate authority and responsibility to do so.

## **3. DISSEMINATION OF POLICY:**

All members of the CONTRACTOR's staff who are authorized to hire, supervise, promote, and discharge employees, or who recommend such action, or who are substantially involved in such action, will be made fully cognizant of, and will implement, the CONTRACTOR's EEO policy and contractual responsibilities to provide EEO in each grade and classification of employment. To ensure that the above agreement will be met, the following actions will be taken as a minimum:

Periodic meetings of supervisory and personnel office employees will be conducted before the start of work and then not less often than once every six months, at which time the CONTRACTOR's EEO policy and its implementation will be reviewed and explained. The meetings will be conducted by the EEO officer.

All new supervisory or personnel office employees will be given a thorough indoctrination by the EEO Officer, covering all major aspects of the CONTRACTOR's EEO obligations within thirty days following their reporting for duty with the CONTRACTOR.

All personnel who are engaged in direct recruitment for the project will be instructed by the EEO Officer in the CONTRACTOR's procedures for locating and hiring minority employees.

Notices and posters identifying the CONTRACTOR's EEO policy will be placed in areas readily accessible to employees, applicants for employment and potential employees.

The CONTRACTOR's EEO policy and the procedures to implement such policy will be brought to the attention of employees by means of meetings, employee handbooks, or other appropriate means.

#### **4. RECRUITMENT OF EMPLOYEES:**

When advertising for employees, the CONTRACTOR will include in all advertisements for employees the notation: "An Equal Opportunity Employer." All such advertisements will be placed in publications having a large circulation among minority groups in the area from which the project work force would normally be derived.

The CONTRACTOR will, unless precluded by a valid bargaining agreement, conduct systematic and direct recruitment through public and private employee referral sources likely to yield qualified minority group applicants. To meet this requirement, the CONTRACTOR will identify sources of potential minority group employees, and establish with such identified sources procedures whereby minority group applicants may be referred to the CONTRACTOR for employment consideration.

In the event the CONTRACTOR has a valid bargaining agreement providing for exclusive hall referrals, he is expected to observe the provisions of that agreement to the extent that the system permits the CONTRACTOR's compliance with EEO contract provisions. (The DOL has held that where implementations of such agreements have the effect of discriminating against minorities or women, or obligates the CONTRACTOR to do the same, such implementation violates Executive Order 11246, as amended.)

The CONTRACTOR will encourage his present employees to refer minority group applicants for employment. Information and procedures with regard to referring minority group applicants will be discussed with employees.

#### **5. SELECTION OF SUBCONTRACTORS, PROCUREMENT OF MATERIALS AND LEASING OF EQUIPMENT:**

The CONTRACTOR shall not discriminate on the grounds of race, color, religion, sex, national origin, age or disability in the selection and retention of subCONTRACTORS, including procurement of materials and leases of equipment.

The CONTRACTOR shall notify all potential subCONTRACTORS and suppliers of his/her EEO obligations under this contract.

Disadvantaged business enterprises (DBE) as defined in 49 CFR 23, shall have equal opportunity to compete for and perform subcontracts, which the CONTRACTOR enters into pursuant to this contract. The CONTRACTOR will use his best efforts to solicit bids from and to utilize DBE subCONTRACTORS or subCONTRACTORS with meaningful minority group and female representation among their employees.

The CONTRACTOR will use his best efforts to ensure subCONTRACTOR compliance with their EEO obligations.

#### **6. EEO RECORDS AND REPORTS:**

The CONTRACTOR shall keep such records as necessary to document compliance with the EEO requirements. Such records shall be retained for a period of five years following completion of the contract work and shall be

available at reasonable times and places for inspection by authorized representatives. The records kept by the CONTRACTOR shall document the following:

The number of minority and non-minority group members and women employed in each work classification on the project; The progress and efforts being made in cooperation with unions, when applicable, to increase employment opportunities for minorities and women; The progress and efforts being made in locating, hiring, training, qualifying, and upgrading minority and female employees; and The progress and efforts being made in securing the services of DBE subcontractors or subcontractors with meaningful minority and female representation among their employees.

#### **7. NONSEGREGATED FACILITIES:**

Applicable to all Federal-aid construction contracts and to all related subcontracts of \$10,000 or more. By the execution of this contract or subcontract, or the consummation of this material supply agreement or purchase order, all parties certify that the firm does not maintain or provide for its employees any segregated facilities at any of its establishments, and that the firm does not permit its employees to perform their services at any location under its control, where segregated facilities are maintained. The CONTRACTOR agrees that a breach of this certification is a violation of the EEO provisions of this contract. The CONTRACTOR further certifies that no employee will be denied access to adequate facilities on the basis of sex or disability.

As used in this certification, the term "segregated facilities" refers to facilities provided for employees which are segregated by explicit directive, or on the basis of race, color, religion, national origin, age or disability, because of habit, local custom, or otherwise. The only exception will be for the disabled when the demands for accessibility override, (e.g. disabled parking).

The CONTRACTOR agrees that it has obtained or will obtain identical certification from proposed subcontractors or material suppliers prior to award of subcontracts or consummation of material supply agreements of \$10,000 or more and that it will retain such certifications in its files.

#### **8. FALSIFICATION OF DOCUMENTS:**

The falsification of any of the above certifications may subject the CONTRACTOR to civil or criminal prosecution under 18 U.S.C. 1001 and 31 U.S.C. 231.

The CONTRACTOR or subCONTRACTOR shall make the records required available for inspection, copying, or transcription by authorized representatives of the awarding agency or the DOL, and shall permit such representatives to interview employees during working hours on the job. If the CONTRACTOR or subCONTRACTOR fails to submit the required records or to make them available, the awarding agency, HUD or DOL, or all may, after written notice to the CONTRACTOR, sponsor, applicant, or owner, take such actions as may be necessary to cause the suspension of any further payment, advance, or guarantee of funds. Furthermore, failure to submit the required records upon request or to make such records available may be grounds of debarment action pursuant to 29 CRF 5.12.

#### **9. SECTION 3**

The purpose of Section 3 requires the CONTRACTOR and subcontractors to provide jobs and other economic opportunities to low-income persons. The CDBG project service area for Section 3 compliance will be the metropolitan statistical area.

The CONTRACTOR and subcontractor participating in federally assisted projects are required to track and report their activity relative to the hiring and training of low and moderate-income persons and the use of local businesses owned by low-income persons. This information must be reported by the CONTRACTOR and subcontractors prior to project completion utilizing the "Section 3: Economic Opportunities for Low and Very Low Income Persons" forms attached under Section 5 - Attachment 5.

All Section 3 covered contracts shall include the following Section 3 clause consisting of Items A-F:

- A. The work to be performed under this contract is subject to the requirements of Section 3 of the Housing and Urban Development Act of 1968, as amended, 12 U.S.C. 1701u (Section 3). The purpose of Section 3 is to ensure that employment and other economic opportunities generated by HUD assistance or HUD-assisted projects covered by Section 3, shall, to the greatest extent feasible, be directed to low- and very low-income persons, particularly persons who are recipients of HUD assistance for housing.
- B. The parties to this contract agree to comply with this Section in 24 CFR part 135, which implement Section 3. As evidenced by their execution of this contract, the parties to this contract certify that they are under no contractual or other impediment that would prevent them from complying with these regulations.
- C. The CONTRACTOR agrees to notify each labor organization or representative workers with which the CONTRACTOR has a collective bargaining agreement or other contract or other understanding, if any, a notice advising the labor organization or workers representative of the CONTRACTOR's commitments under this Section 3 clause, and will post copies of the notice in conspicuous places at the work site where both employees and applicants for training and employment positions can see the notice. The notice shall describe the Section 3 preferences, shall set forth minimum number of job titles subject to hire, availability of apprentice-ship and training positions, the qualifications for each, and the name and location of the person(s) taking applications for each of the positions, and the anticipated date the work shall begin.
- D. The CONTRACTOR agrees to include the Section 3 clause in every subcontract subject to compliance with regulations 24 CFR part 135, and agrees to take appropriate action, as provided in an applicable provision on the subcontract or in this Section 3 clause, upon a finding that that subcontractor is in violation or the regulations in 24 CFR part 135. The CONTRACTOR will not subcontract with any subcontractor where the CONTRACTOR has notice or knowledge that the subcontractor has been found in violation of the regulations in 24 CFR part 135.
- E. The CONTRACTOR will certify that any vacant employment positions, including training positions, that are filled after the CONTRACTOR is selected but before the contract is executed with persons other than those to whom the regulations of 24 CFR Part 135 require employment opportunities to be directed, were not filled to circumvent the CONTRACTOR's obligations under this section of the Code of Federal Regulations.
- F. Noncompliance with HUD's regulations in this Part may result in sanctions, termination of this contract for default, and debarment or suspension from future HUD assisted contracts.

## **10. OFFICE OF FEDERAL CONTRACT COMPLIANCE (OFCCP)**

For this federally assisted construction contract, the OFCCP administers and enforces Executive Order 11246, as amended. This Order prohibits discrimination and requires affirmative action to ensure equal employment opportunity without regard to race, color, sex, religion and/or national origin; and the implementing regulations at 41 CFR Parts 60-1 through 60-50. Generally, all CONTRACTORS and subCONTRACTORS holding nonexempt federally assisted construction contracts and subcontracts exceeding \$10,000 must comply with Executive Order 11246.

A "Notice of Requirement for Affirmative Action to Ensure Equal Employment Opportunity" (Executive Order 11246) is to be included in the bid solicitations for all federally assisted construction contracts and subcontracts in excess of \$10,000. The Notice, which is published at 41 CFR 60-4.2, informs the CONTRACTOR/bidder of the affirmative action requirements imposed under Executive Order 11246, including the specified goals for minority and female participation.



Covered federally assisted construction contracts and subcontracts must incorporate the equal opportunity clause found at 41 CFR 60-1.4(b).

The equal opportunity clause may be expressly included in each contract or subcontract or incorporated by reference. Importantly, the equal opportunity clauses are deemed to be a part of every covered construction contract and subcontract even if they are not physically incorporated in the contract documents.

In addition to the equal opportunity clauses, federally assisted construction contracts and subcontracts in excess of \$10,000 must include the "Standard Federal Equal Employment Opportunity Construction Contract Specifications" which are found at 41 CFR 60-4.3. The specifications describe the affirmative action obligations and set forth the specific affirmative action steps the construction CONTRACTOR must implement in order to make a good faith effort to achieve the goals for minority and female participation that were listed in the bid solicitation.

Additional information regarding OFCCP Compliance may be found at [www.dol.gov/esa/OFCCP](http://www.dol.gov/esa/OFCCP) or, at 1-800-397-6251. The Indiana office is located at 46 East Ohio Street, Suite 419, Indianapolis, IN 46204 and phone number is 317-226-5860.

## 11. Compliance with Rehabilitation Act of 1973

A. AFFIRMATIVE ACTION FOR WORKERS WITH DISABILITIES (Pursuant to Section 503 and 504 of the Rehabilitation Act of 1973, 29 U.S.C. §§793 and 794); Definition: "Individual with disability" means any person who has a physical or mental impairment that substantially limits one or more major life activities; has a record of such an impairment; or is regarded as having such an impairment, as provided in 29 U.S.C. §706(8)(B). For purposes of employment, this term does not include: Any individual who is currently engaging in the illegal use of drugs, as provided in 29 U.S.C. §706(8)(C), or any individual who is an alcoholic whose current use of alcohol prevents the individual from performing the duties of the job in question, or whose employment, by reason of current alcohol abuse, would constitute a direct threat to property or the safety of others, as provided in 29 U.S.C. §706(8)(C)(v); or any individual who has a currently contagious disease or infection and who, by reason of such disease or infection, would constitute a direct threat to the health or safety of other individuals or who, by reason of the currently contagious disease or infection, is unable to perform the duties of the job (as provided in 29 U.S.C. §706(8)(D)).

1. The CONTRACTOR will not discriminate against any employee because of disability in regard to any position for which the employee or applicant for employment is qualified. The CONTRACTOR agrees to take affirmative action to employ, advance in employment and otherwise treat qualified individuals with disabilities without discrimination based upon their physical or mental disability in all employment practices such as the following: employment, up-grading, demotion or transfer, recruitment, advertising, layoff or termination, rates of pay or other forms of compensation and selection for training including apprenticeship.
2. The CONTRACTOR agrees to comply with the rules, regulations and relevant orders of the Secretary of Labor issued pursuant to the Act.
3. In the event of the CONTRACTOR's noncompliance with the requirements of this clause, actions for noncompliance may be taken in accordance with the rules, regulations and relevant orders of the Secretary of Labor issued pursuant to the Act.
4. The CONTRACTOR agrees to post in conspicuous places available to employees and applicants for employment notices in a form to be prescribed by the Director, provided by or through the contracting officer. Such notices shall state the CONTRACTOR's obligation under the law to take affirmative action to employ and advance in employment qualified handicapped employees and applicants for employment and the rights of applicants and employees.

5. The CONTRACTOR will notify each labor union or representative of workers with which it has a collective bargaining agreement or other contract understanding that the CONTRACTOR is bound by the terms of Section 503 of the Rehabilitation Act of 1973 and is committed to take affirmative action to employ and advance in employment physically and mentally handicapped individuals.
6. The CONTRACTOR will include the provisions of this clause in every subcontract or purchase order of \$2,500 or more unless exempted by rules, regulations or orders of the Secretary issued pursuant to section 503 of the Act so that such provisions will be binding upon each subcontractor or vendor. The CONTRACTOR will take such action with respect to any subcontract or purchase order as the Director of the Office of Federal Contract Compliance Programs may direct to enforce such provisions, including action for noncompliance.

### **SECTION 3 Federal Labor Standards Regulations**

Any and all CONTRACTORS, subcontractors, independent CONTRACTORS, suppliers, facilitators or any person participating in any program or activity receiving federal financial assistance shall:

The attached **Notice to All Employees Poster on Federally Assisted Projects** must be posted on the worksite during the entirety of the project. See **Section 5- Attachment 6**.

Comply with federal labor standards regulations as follows:

1. Davis-Bacon Act
2. **Wage Decision attached under Section 5 – Attachment 7.**
3. Contract Work Hours and Safety Standards Act
4. Copeland Act (Anti-Kickback Act)
5. Fair Labor Standards Act
6. **Payroll Format attached under Section 5 – Attachment 8**

The U. S. Department of Labor has published rules and regulations corresponding to the above regulations at Title 29 CFR Parts 1, 3, 5, 6 and 7.

#### **1. CERTIFICATION REGARDING DEBARMENT, SUSPENSION, INELIGIBILITY AND VOLUNTARY EXCLUSION PRIMARY COVERED TRANSACTIONS:**

(Applicable to all Federal-aid contracts 49 CFR 29)

By signing and submitting this proposal, the contractor is providing the certification set out below. The inability of a person to provide the certification set out below will not necessarily result in denial of participation in this covered transaction. The CONTRACTOR shall submit an explanation of why it cannot provide the certification set out below. The certification or explanation will be considered in connection with the department or agency's determination whether to enter into this transaction. However, failure of the CONTRACTOR to furnish a certification or an explanation shall disqualify such a person from participation in this transaction.

The certification in this clause is a material representation of fact upon which reliance was placed when the department or agency determined to enter into this transaction. If it is later determined that the CONTRACTOR knowingly rendered an erroneous certification, in addition to other remedies available to the Federal Government, the department or agency may terminate this transaction for cause or default.

The CONTRACTOR shall provide immediate written notice to the department or agency to which this proposal is submitted if any time the CONTRACTOR learns that its certification was erroneous when submitted or has become erroneous by reason of changed circumstances.

The terms "covered transaction", "debarred", "suspended", "ineligible", "lower tier covered transaction", "participant", "person", "primary covered transaction," "principal," "proposal," and "voluntarily excluded," as used in this clause, have the meanings set out in the Definitions and Coverage sections of rules implementing Executive Order 12549. You may contact the department or agency to which this proposal is submitted for assistance in obtaining a copy of those regulations.

The CONTRACTOR agrees by submitting this proposal that, should the proposed covered transaction be entered into, it shall not knowingly enter into any lower tier covered transaction with a person who is debarred, suspended, declared ineligible, or voluntarily excluded from participation in this covered transaction, unless authorized by the department or agency entering into this transaction.

The CONTRACTOR further agrees by submitting this proposal that it will include the clause titled "Certification Regarding Debarment, Suspension, Ineligibility and Voluntary Exclusion-Lower Tier Covered Transaction," provided by the department or agency entering into this covered transaction, without modification, in all lower tier covered transactions and in all solicitations for lower tier covered transactions.

The City covered transaction will rely upon a certification of a CONTRACTOR in a lower tier covered transaction that is not debarred, suspended, ineligible, or voluntarily excluded from the covered transaction, unless it knows that the certification is erroneous. A CONTRACTOR may decide the method and frequency by which it determines the eligibility of its principals. Each CONTRACTOR may, but is not required to, check the nonprocurement portion of the "Lists of Parties Excluded From Federal Procurement or Nonprocurement Programs" (Nonprocurement List), which is compiled by the General Services Administration.

Nothing contained in the foregoing shall be construed to require establishment of a system of records in order to render in good faith the certification required by this clause. The knowledge and information of CONTRACTOR is not required to exceed that which is normally possessed by a prudent person in the ordinary course of business dealings.

If a CONTRACTOR in a covered transaction knowingly enters into a lower tier covered transaction with a person who is suspended, debarred, ineligible, or voluntarily excluded from participation in this transaction, in addition to other remedies available to the Federal Government, the department or agency may terminate this transaction for cause or default.

The prospective primary participant certifies to the best of its knowledge and belief, that it and its principals:  
Are not presently debarred, suspended, proposed for debarment, declared ineligible, or voluntarily excluded from covered transactions by any Federal department or agency;

Have not within a 3-year period preceding this proposal been convicted of or had a civil judgment rendered against them for commission of fraud or a criminal offense in connection with obtaining, attempting to obtain, or performing a public (Federal, State or local) transaction or contract under a public transaction; violation of Federal or State antitrust statutes or commission of embezzlement, theft, forgery, bribery, falsification or destruction of records, making false statement, or receiving stolen property.

Are not presently indicted for or otherwise criminally or civilly charged by a governmental entity (Federal, State or local) with commission of any of the offenses enumerated in this certification; and Have not within a 3-year period preceding this application/proposal had one or more public transactions (Federal, State or local) terminated for cause or default.

Where the CONTRACTOR is unable to certify to any of the statements in this certification, such prospective participant shall attach an explanation to this proposal.

**2. CERTIFICATION REGARDING DEBARMENT, SUSPENSION, INELIGIBILITY AND VOLUNTARY EXCLUSION APPLICABLE TO ALL SUBCONTRACTS, PURCHASE ORDERS AND OTHER LOWER TIER TRANSACTIONS OF \$25,000 OR MORE**

By signing and submitting this proposal, the CONTRACTOR and subCONTRACTOR providing the certification set out below.

The certification in this clause is a material representation of fact upon which reliance was placed when this transaction was entered into. If it is later determined that the prospective lower tier participant knowingly rendered an erroneous certification, in addition to other remedies available to the Federal Government, the department, or agency with which this transaction originated may pursue available remedies, including suspension and/or debarment.

The prospective lower tier subCONTRACTOR shall provide immediate written notice to the person to which this proposal is submitted if at any time the subCONTRACTOR learns that its certification was erroneous by reason of changed circumstances.

The terms "covered transaction," "debarred," "suspended," "ineligible," "primary covered transaction," "participant," "person," "principal," "proposal," and "voluntarily excluded," as used in this clause, have the meanings set out in the Definitions and Coverage sections of rules implementing Executive Order 12549. You may contact the person to which this proposal is submitted for assistance in obtaining a copy of those regulations.

The CONTRACTOR and subCONTRACTOR agrees by submitting this proposal that, should the proposed covered transaction be entered into, it shall not knowingly enter into any lower tier covered transaction with a person who is debarred, suspended, declared ineligible, or voluntarily excluded from participation in this covered transaction, unless authorized by the department or agency with which this transaction originated.

The CONTRACTOR and subCONTRACTOR further agrees by submitting this proposal that it will include this clause titled "Certification Regarding Debarment, Suspension, Ineligibility and Voluntary Exclusion-Lower Tier Covered Transaction," without modification, in all lower tier covered transactions and in all solicitations for lower tier covered transactions.

A CONTRACTOR in a covered transaction may rely upon a certification of a prospective participant in a lower tier covered transaction that is not debarred, suspended, ineligible, or voluntarily excluded from the covered transaction, unless it knows that the certification is erroneous. A participant may decide the method and frequency by which it determines the eligibility of its principals. Each participant may, but is not required to, check the Nonprocurement List.

Nothing contained in the foregoing shall be construed to require establishment of a system of records in order to render in good faith the certification required by this clause. The knowledge and information of participant is not required to exceed that which is normally possessed by a prudent person in the ordinary course of business dealings.

If a CONTRACTOR in a covered transaction knowingly enters into a lower tier covered transaction with a person who is suspended, debarred, ineligible, or voluntarily excluded from participation in this transaction, in addition to other remedies available to the Federal Government, the department or agency with which this transaction originated may pursue available remedies, including suspension and/or debarment.

The CONTRACTOR and subCONTRACTOR certifies, by submission of this proposal, that neither it nor its principals is presently debarred, suspended, proposed for debarment, declared ineligible, or voluntarily excluded from participation in this transaction by any Federal department or agency.

Where the CONTRACTOR and subCONTRACTOR are unable to certify to any of the statements in this certification, such prospective participant shall attach an explanation to this proposal.

### 3. PAYMENT OF PREVAILING WAGES:

Applicable to all Federal-aid (CDBG) construction contracts exceeding \$2,000 and to all related subcontracts:

All mechanics and laborers employed or working upon the site of the work will be paid unconditionally and not less often than once a week and without subsequent deduction or rebate on any account except such payroll deductions as are permitted by regulations (29 CFR 3) issued by the Secretary of Labor under the Copeland Act (40 U.S.C. 276c) the full amounts of wages and bona fide fringe benefits or cash equivalents thereof due at time of payment. The payment shall be computed at wage rates not less than those contained in the wage determination of the Secretary of Labor, hereinafter called "the wage determination", which is attached hereto and made a part hereof, regardless of any contractual relationship which may be alleged to exist between the CONTRACTOR or its subCONTRACTORS and such laborers and mechanics. The wage determination shall be posted at all times by the CONTRACTOR and its subCONTRACTORS at the site of the work in a prominent and accessible place where it can be easily seen by the workers. For the purpose of this Section, contributions made or costs reasonably anticipated for bona fide fringe benefits under Section 1 (b)(2) of the Davis-Bacon Act (40 U.S.C. 276a) on behalf of laborers or mechanics are considered wages paid. Regular contributions made or costs incurred for more than a weekly period (but not less often than quarterly) under plans, funds, or programs, which cover the particular weekly period, are deemed to be constructively made or incurred during such weekly period. Such laborers and mechanics shall be paid the appropriate wage rate and fringe benefits on the wage determination for the classification of work actually performed, without regard to skill.

Laborers or mechanics performing work in more than one classification may be compensated at the rate specified for each classification for the time actually worked therein, provided, that the employer's payroll records accurately set forth the time spent in each classification in which work is performed.

All rulings and interpretations of the Davis-Bacon Act and related acts contained in 29 CFR 1, 3 and 5 are herein incorporated by reference in this contract.

### 4. PERSONNEL ACTIONS:

Wages, working conditions, and employee benefits shall be established and administered, and personnel actions of every type including hiring, upgrading, promotion, transfer, demotion, layoff, and termination, shall be taken without regard to race, color, religion, sex, national origin, age or disability. The following procedures shall be followed:

The CONTRACTOR will conduct periodic inspections of project sites to insure that working conditions and employee facilities do not indicate discriminatory treatment of project site personnel.

The CONTRACTOR will periodically evaluate the spread of wages paid within each classification to determine any evidence of discriminatory wage practices.

The CONTRACTOR will periodically review selected personnel actions in depth to determine whether there is evidence of discrimination. Where evidence is found, the CONTRACTOR will promptly take corrective action. If the review indicates that the discrimination may extend beyond the actions reviewed, such corrective action shall include all affected persons.

The CONTRACTOR will promptly investigate all complaints of alleged discrimination made to the CONTRACTOR in connection with his obligations under this contract, will attempt to resolve such complaints, and will take appropriate corrective action within a reasonable time. If the investigation indicates that the discrimination may affect persons other than the complainant, such corrective action shall include such other persons. Upon completion of each investigation, the CONTRACTOR will inform every complainant of all of his avenues of appeal.

The CONTRACTOR will assist in locating, qualifying, and increasing the skills of minority group and women employees, and applicants for employment.

#### **5. CONFORMANCE RATES:**

The awarding agency shall require that any class of laborers or mechanics employed under the contract, which is not listed in the wage determination, shall be classified in conformance with the wage decision.

An additional classification, wage rate and fringe benefits may be approved only when the following criteria have been met:

- (1) The work to be performed by the additional classification is not performed by any other classification in the wage determination;
- (2) The additional classification is utilized in the area by the construction industry;
- (3) The proposed wage rate, including any bona fide fringe benefits, bears a reasonable relationship to the wage rates contained in the wage determination.

If the CONTRACTOR or subCONTRACTOR, laborers and mechanics, awarding agency and the contracting officer agree on the classification and conformance wage rate including the amount designated for fringe benefits where appropriate, the conformance rates shall be paid to all workers performing work in that classification from the first day on which work is performed in the classification.

In the event the CONTRACTOR or subCONTRACTORS, laborers and mechanics, awarding agency and the contracting officer do not agree on the proposed classification and wage rate including the amount designated for fringe benefits where appropriate, the contracting officer (OCRA Labor Standards Compliance Officer) shall refer the questions, including the views of all interested parties and the recommendation of the contracting officer, to the Wage and Hour Administrator for determination. Said Administrator, or an authorized representative, will issue a determination within 30 days of receipt and so advise the contracting agency or will notify within the 30-day period that additional time is necessary. Any work performed during the waiting period will be paid at the base wage and fringe benefit amount conditionally assigned by the contracting officer until a conformance rate is assigned by the Wage and Hour Administrator.

#### **6. PAYMENT OF FRINGE BENEFITS:**

Whenever the minimum wage rate prescribed in the contract for a class of laborers or mechanics includes a fringe benefit which is not expressed as an hourly rate, the CONTRACTOR or subCONTRACTORS, as appropriate, shall either pay the benefit as stated in the wage determination or shall pay another bona fide fringe benefit or an hourly case equivalent thereof. If the CONTRACTOR or subCONTRACTOR does not make payments to a trustee or other third person, he/she may consider as a part of the wages of any laborer or mechanic the amount of any costs reasonably anticipated in providing bona fide fringe benefits under a plan or program, provided that the Secretary of Labor has found, upon the written request of the CONTRACTOR, that the applicable standards of the Davis-Bacon Act have been met.

#### **7. APPRENTICE PARTICIPATION:**

Apprentices will be permitted to work at less than the predetermined rate for the work they perform when they are employed pursuant to and individually registered in a bona fide apprenticeship program duly registered with the DOL, Employment and Training Administration, Bureau of Apprenticeship and Training, or with a State apprenticeship agency recognized by the Bureau.

The allowable ratio of apprentices to journeyman-level employees on the job site in any craft classification shall not be greater than the ratio permitted to the CONTRACTOR as to the entire work force under the registered program. Any employee listed on a payroll at an apprentice wage rate, who is not registered or otherwise employed as stated above, shall be paid not less than the applicable wage rate listed in the wage determination for the classification of work actually performed. In addition, any apprentice performing work on the job site in excess of the ratio permitted under the registered program shall be paid not less than the applicable wage rate on the wage determination for the work actually performed. Where a CONTRACTOR or subCONTRACTOR is performing construction on a project in a locality other than that in which its program is registered, the ratios and wage rates (expressed in percentages of the journeyman-level hourly rate) specified in the CONTRACTOR's or subCONTRACTOR's registered program should be observed. Every apprentice must be paid at not less than the rate specified in the registered program for the apprentice's level of progress, expressed as a percentage of the journeyman level hourly rate specified in the applicable wage determination. Apprentices shall be paid fringe benefits in accordance with the provisions of the apprenticeship program. If the apprenticeship program does not specify fringe benefits, apprentices must be paid the full amount of fringe benefits listed on the wage determination for the applicable classification. If the Administrator for the Wage and Hour Division determines that a different practice prevails for the applicable apprentice classification, fringes shall be paid in accordance with that determination. In the event the Bureau of Apprenticeship and Training, or a State apprenticeship agency recognized by the Bureau, withdraws approval of an apprenticeship program, the CONTRACTOR or subCONTRACTOR will no longer be permitted to utilize apprentices at less than the applicable predetermined rate for the comparable work performed by regular employees until an acceptable program is approved.

#### **8. OVERTIME REQUIREMENTS:**

No CONTRACTOR or subCONTRACTOR contracting for any part of the contract work which may require or involve the employment of laborers, mechanics, watchmen, or guards (including apprentices) shall require or permit any laborer, mechanic, watchman, guard or apprentice in any workweek in which he/she is employed on such work, to work in excess of 40 hours in such workweek unless such laborer, mechanic, watchman, guard or apprentice receives compensation at a rate not less than one-and-one-half times his/her basic rate of pay for all hours worked in excess of 40 hours in such workweek.

#### **9. WITHHOLDING PAYMENT FOR UNPAID WAGES:**

The awarding agency shall upon its own action or upon written request of an authorized representative of the DOL withhold, or cause to be withheld, from the CONTRACTOR or subCONTRACTOR under this contract or any other Federal contract with the same prime CONTRACTOR, or any other Federally-assisted contract subject to Davis-Bacon prevailing wage requirements which is held by the same prime CONTRACTOR, as much of the accrued payments or advances as may be considered necessary to pay laborers and mechanics employed by the CONTRACTOR or any subCONTRACTOR the full amount of wages required by the contract. In the event of failure to pay any laborer or mechanic employed or working on the site of the work, all or part of the wages required by the contract, the contracting agency may, after written notice to the CONTRACTOR, take such action as may be necessary to cause the suspension of any further payment, advance, or guarantee of funds until such violations have ceased.

#### **10. VIOLATIONS AND LIABILITY FOR UNPAID WAGES AND LIQUIDATED DAMAGES:**

In the event of any violation of the requirements set forth in this document, the CONTRACTOR and any subCONTRACTOR responsible for the violation shall be liable to the affected employee for his/her unpaid wages. In addition, such CONTRACTOR and subCONTRACTOR shall be liable to the United States for liquidated damages.

## 11. STATEMENTS AND PAYROLLS:

Applicable to all Federally assisted construction contracts exceeding \$2,000 and to all related subcontracts, except for projects located on roadways classified as local roads or rural collectors, which are exempt.

The CONTRACTOR shall comply with the Copeland Regulations of the Secretary of Labor.

Payrolls and basic records relating thereto shall be maintained by the CONTRACTOR and each subCONTRACTOR during the course of the work and preserved for a period of 5 years from the date of completion of the contract for all laborers, mechanics, apprentices, watchmen, helpers and guards working at the site of the work.

The payroll records shall contain the name, social security number, and address of each such employee; his or her correct classification; hourly rates of wages paid (including rates of contributions or costs anticipated for bona fide fringe benefits or cash equivalent thereof of the types described in Section 1(b)(2)(B) of the Davis Bacon Act); daily and weekly number of hours worked; deductions made; and actual wages paid. Whenever the Secretary of Labor has found that the wages of any laborer or mechanic include the amount of any costs reasonably anticipated in providing benefits under a plan or program described in Section 1(b)(2)(B) of the Davis Bacon Act, the CONTRACTOR and subCONTRACTOR shall maintain records which show that the commitment to provide such benefits is enforceable, that the plan or program is financially responsible, that the plan or program has been communicated in writing to the laborers or mechanics affected, and show the cost anticipated or the actual cost incurred in providing benefits. CONTRACTORS or subCONTRACTORS employing apprentices under approved programs shall maintain written evidence of the registration of apprentices and ratios and wage rates prescribed in the applicable programs.

Each CONTRACTOR and subCONTRACTOR shall furnish, each week in which any contract work is performed, to the awarding agency or an agent thereof, a certified payroll report of wages paid each of its employees. The payroll submitted shall set out accurately and completely all of the information required to be maintained. This information may be submitted in any form desired. Optional Form WH-347 is available for this purpose and may be purchased from the Superintendent of Documents (Federal stock number 029-005-0014-1), U.S. Government Printing Office, Washington, D.C. 20402. The prime CONTRACTOR is responsible for the submission of copies of payrolls by all subCONTRACTORS.

Each payroll submitted shall be accompanied by a "Statement of Compliance," signed by the CONTRACTOR or subCONTRACTOR or his/her agent who pays or supervises the payment of the persons employed under the contract and shall certify the following:

That the payroll for the payroll period contains the information required to be maintained and that such information is correct and complete;

That such laborer or mechanic employed on the contract during the payroll period has been paid the full weekly wages earned, without rebate, either directly or indirectly, and that no deductions have been made either directly or indirectly from the full wages earned, other than permissible deductions as set forth in the Regulations, 29 CFR 3;

That each laborer or mechanic has been paid not less than the applicable wage rate and fringe benefits or cash equivalent for the classification of work performed, as specified in the applicable wage determination incorporated into the contract.

The weekly submission of a properly executed certification set forth on the reverse side of Optional Form WH-347 shall satisfy the requirement for submission of the "Statement of Compliance".

## SECTION 4 Health and Safety



## **1. SAFETY AND ACCIDENT PREVENTION:**

In the performance of this contract the CONTRACTOR shall comply with all applicable Federal, State and local laws governing safety, health and sanitation (23 CFR 635). The CONTRACTOR shall provide all safeguards, safety devices and protective equipment and take any other needed actions as it determines, or as the awarding agency may determine, to be reasonably necessary to protect the life and health of employees on the job and the safety of the public and to protect property in connection with the performance of the work covered by the contract.

**The CONTRACTOR must post the poster under Section 5- Attachment 9 at the worksite for all employees to observe.**

It is a condition of this contract, and shall be made a condition of each subcontract, which the CONTRACTOR enters into pursuant to this contract, that the CONTRACTOR and any subCONTRACTOR shall not permit any employee, in performance of the contract, to work in surroundings or under conditions which are unsanitary, hazardous or dangerous to his/her health or safety, as determined under construction safety and health standards (29 CFR 1926) promulgated by the Secretary of Labor, in accordance with Section 107 of the Contract Work Hours and Safety Standards Act (40 U.S.C. 3333).

Pursuant to 29 CFR 1926.3, it is a condition of this contract that the Secretary of Labor or authorized representative thereof, shall have right of entry to any site of contract performance to inspect or investigate the matter of compliance with the construction safety and health standards and to carry out the duties of the Secretary under Section 107 of the Contract Work Hours and Safety Standards Act (40 U.S.C. 333).

## **2. IMPLEMENTATION OF CLEAN AIR ACT AND FEDERAL WATER POLLUTION CONTROL ACT:**

(Applicable to all Federally assisted construction contracts and to all related subcontracts of \$100,000 or more.)

By submission of this bid or the execution of this contract, or subcontract, as appropriate, the bidder, Federal-aid construction CONTRACTOR, or subCONTRACTOR, as appropriate, will be deemed to have stipulated as follows:

That any facility that is or will be utilized in the performance of this contract, unless such contract is exempt under the Clean Air Act, as amended (42 U.S.C. 1857 et seq., as amended by Pub.L. 91-604), and under the Federal Water Pollution Control Act, as amended (33 U.S.C. 1251 et seq., as amended by Pub.L. 92-500), Executive Order 11738, and regulations in implementation thereof (40 CFR 15) is not listed, on the date of contract award, on the U. S. Environmental Protection Agency (EPA) List of Violating Facilities pursuant to 40 CFR 15.20.

That the firm agrees to comply and remain in compliance with all the requirements of Section 114 of the Clean Air Act and Section 308 of the Federal Water Pollution Control Act and all regulations and guidelines listed thereunder.

That the firm shall promptly notify the awarding agency of the receipt of any communication from the Director, Office of Federal Activities, EPA, indicating that a facility that is or will be utilized for the contract is under consideration to be listed on the EPA List of Violating Facilities.

That the firm agrees to include or cause to be included the requirements of this Section in every nonexempt subcontract, and further agrees to take such action as the government may direct as a means of enforcing such requirements.

Attachment # 1

**GOALS FOR WOMEN AND MINORITY UTILIZATION IN CONSTRUCTION**

**These goals apply to all federally assisted construction contracts and subcontracts in excess of \$10,000 (EO 11246). All hours of work (federal and nonfederal) in each trade, regardless of the location of work, are subject to these goals.**

- A. Goals for Women: 6.9%
- B. Goals for Minorities: 8.0%



## ATTACHMENT #3

### Federal Labor Standards Provisions

### U.S. Department of Housing and Urban Development Office of Labor Relations

#### Applicability

The Project or Program to which the construction work covered by this contract pertains is being assisted by the United States of America and the following Federal Labor Standards Provisions are included in this Contract pursuant to the provisions applicable to such Federal assistance.

A. 1. (i) **Minimum Wages.** All laborers and mechanics employed or working upon the site of the work, will be paid unconditionally and not less often than once a week, and without subsequent deduction or rebate on any account (except such payroll deductions as are permitted by regulations issued by the Secretary of Labor under the Copeland Act (29 CFR Part 3), the full amount of wages and bona fide fringe benefits (or cash equivalents thereof) due at time of payment computed at rates not less than those contained in the wage determination of the Secretary of Labor which is attached hereto and made a part hereof, regardless of any contractual relationship which may be alleged to exist between the contractor and such laborers and mechanics. Contributions made or costs reasonably anticipated for bona fide fringe benefits under Section 1(b)(2) of the Davis-Bacon Act on behalf of laborers or mechanics are considered wages paid to such laborers or mechanics, subject to the provisions of 29 CFR 5.5(a)(1)(iv); also, regular contributions made or costs incurred for more than a weekly period (but not less often than quarterly) under plans, funds, or programs, which cover the particular weekly period, are deemed to be constructively made or incurred during such weekly period. Such laborers and mechanics shall be paid the appropriate wage rate and fringe benefits on the wage determination for the classification of work actually performed, without regard to skill, except as provided in 29 CFR 5.5(a)(4). Laborers or mechanics performing work in more than one classification may be compensated at the rate specified for each classification for the time actually worked therein; Provided, That the employer's payroll records accurately set forth the time spent in each classification in which work is performed. The wage determination (including any additional classification and wage rates conformed under 29 CFR 5.5(a)(1)(ii) and the Davis-Bacon poster (WH-1321) shall be posted at all times by the contractor and its subcontractors at the site of the work in a prominent and accessible place where it can be easily seen by the workers.

(ii) (a) Any class of laborers or mechanics which is not listed in the wage determination and which is to be employed under the contract shall be classified in conformance with the wage determination. HUD shall approve an additional classification and wage rate and fringe benefits therefor only when the following criteria have been met:

(1) The work to be performed by the classification requested is not performed by a classification in the wage determination; and

(2) The classification is utilized in the area by the construction industry; and

(3) The proposed wage rate, including any bona fide fringe benefits, bears a reasonable relationship to the wage rates contained in the wage determination.

(b) If the contractor and the laborers and mechanics to be employed in the classification (if known), or their representatives, and HUD or its designee agree on the classification and wage rate (including the amount designated for fringe benefits where appropriate), a report of the action taken shall be sent by HUD or its designee to the Administrator of the Wage and Hour Division, Employment Standards Administration, U.S. Department of Labor, Washington, D.C. 20210. The Administrator, or an authorized representative, will approve, modify, or disapprove every additional classification action within 30 days of receipt and so advise HUD or its designee or will notify HUD or its designee within the 30-day period that additional time is necessary. (Approved by the Office of Management and Budget under OMB control number 1215-0140.)

(c) In the event the contractor, the laborers or mechanics to be employed in the classification or their representatives, and HUD or its designee do not agree on the proposed classification and wage rate (including the amount designated for fringe benefits, where appropriate), HUD or its designee shall refer the questions, including the views of all interested parties and the recommendation of HUD or its designee, to the Administrator for determination. The Administrator, or an authorized representative, will issue a determination within 30 days of receipt and so advise HUD or its designee or will notify HUD or its designee within the 30-day period that additional time is necessary. (Approved by the Office of Management and Budget under OMB Control Number 1215-0140.)

(d) The wage rate (including fringe benefits where appropriate) determined pursuant to subparagraphs (1)(ii)(b) or (c) of this paragraph, shall be paid to all workers performing work in the classification under this contract from the first day on which work is performed in the classification.

(iii) Whenever the minimum wage rate prescribed in the contract for a class of laborers or mechanics includes a fringe benefit which is not expressed as an hourly rate, the contractor shall either pay the benefit as stated in the wage determination or shall pay another bona fide fringe benefit or an hourly cash equivalent thereof.

(iv) If the contractor does not make payments to a trustee or other third person, the contractor may consider as part

of the wages of any laborer or mechanic the amount of any costs reasonably anticipated in providing bona fide fringe benefits under a plan or program. Provided, That the Secretary of Labor has found, upon the written request of the contractor, that the applicable standards of the Davis-Bacon Act have been met. The Secretary of Labor may require the contractor to set aside in a separate account assets for the meeting of obligations under the plan or program. (Approved by the Office of Management and Budget under OMB Control Number 1215-0140.)

2. Withholding. HUD or its designee shall upon its own action or upon written request of an authorized representative of the Department of Labor withhold or cause to be withheld from the contractor under this contract or any other Federal contract with the same prime contractor, or any other Federally-assisted contract subject to Davis-Bacon prevailing wage requirements, which is held by the same prime contractor so much of the accrued payments or advances as may be considered necessary to pay laborers and mechanics, including apprentices, trainees and helpers, employed by the contractor or any subcontractor the full amount of wages required by the contract in the event of failure to pay any laborer or mechanic, including any apprentice, trainee or helper, employed or working on the site of the work, all or part of the wages required by the contract. HUD or its designee may, after written notice to the contractor, sponsor, applicant, or owner, take such action as may be necessary to cause the suspension of any further payment, advance, or guarantee of funds until such violations have ceased. HUD or its designee may, after written notice to the contractor, disburse such amounts withheld for and on account of the contractor or subcontractor to the respective employees to whom they are due. The Comptroller General shall make such disbursements in the case of direct Davis-Bacon Act contracts.

3. (i) Payrolls and basic records. Payrolls and basic records relating thereto shall be maintained by the contractor during the course of the work preserved for a period of three years thereafter for all laborers and mechanics working at the site of the work. Such records shall contain the name, address, and social security number of each such worker, his or her correct classification, hourly rates of wages paid (including rates of contributions or costs anticipated for bona fide fringe benefits or cash equivalents thereof of the types described in Section 1(b)(2)(B) of the Davis-Bacon Act), daily and weekly number of hours worked, deductions made and actual wages paid. Whenever the Secretary of Labor has found under 29 CFR 5.5 (a)(1)(iv) that the wages of any laborer or mechanic include the amount of any costs reasonably anticipated in providing benefits under a plan or program described in Section 1(b)(2)(B) of the Davis-Bacon Act, the contractor shall maintain records which show that the commitment to provide such benefits is enforceable, that the plan or program is financially responsible, and that the plan or program has been

communicated in writing to the laborers or mechanics affected, and records which show the costs anticipated or the actual cost incurred in providing such benefits. Contractors employing apprentices or trainees under approved programs shall maintain written evidence of the registration of apprenticeship programs and certification of trainee programs, the registration of the apprentices and trainees, and the ratios and wage rates prescribed in the applicable programs. (Approved by the Office of Management and Budget under OMB Control Numbers 1215-0140 and 1215-0017.)

(ii) (a) The contractor shall submit weekly for each week in which any contract work is performed a copy of all payrolls to HUD or its designee if the agency is a party to the contract, but if the agency is not such a party, the contractor will submit the payrolls to the applicant sponsor, or owner, as the case may be, for transmission to HUD or its designee. The payrolls submitted shall set out accurately and completely all of the information required to be maintained under 29 CFR 5.5(a)(3)(i) except that full social security numbers and home addresses shall not be included on weekly transmittals. Instead the payrolls shall only need to include an individually identifying number for each employee (e.g., the last four digits of the employee's social security number). The required weekly payroll information may be submitted in any form desired. Optional Form WH-347 is available for this purpose from the Wage and Hour Division Web site at <http://www.dol.gov/esa/whd/forms/wh347instr.htm> or its successor site. The prime contractor is responsible for the submission of copies of payrolls by all subcontractors. Contractors and subcontractors shall maintain the full social security number and current address of each covered worker, and shall provide them upon request to HUD or its designee if the agency is a party to the contract, but if the agency is not such a party, the contractor will submit the payrolls to the applicant sponsor, or owner, as the case may be, for transmission to HUD or its designee, the contractor, or the Wage and Hour Division of the Department of Labor for purposes of an investigation or audit of compliance with prevailing wage requirements. It is not a violation of this subparagraph for a prime contractor to require a subcontractor to provide addresses and social security numbers to the prime contractor for its own records, without weekly submission to HUD or its designee. (Approved by the Office of Management and Budget under OMB Control Number 1215-0149.)

(b) Each payroll submitted shall be accompanied by a "Statement of Compliance," signed by the contractor or subcontractor or his or her agent who pays or supervises the payment of the persons employed under the contract and shall certify the following:

(1) That the payroll for the payroll period contains the information required to be provided under 29 CFR 5.5 (a)(3)(i), the appropriate information is being maintained under 29 CFR 5.5(a)(3)(i), and that such information is correct and complete;

(2) That each laborer or mechanic (including each helper, apprentice, and trainee) employed on the contract during the payroll period has been paid the full weekly wages earned, without rebate, either directly or indirectly, and that no deductions have been made either directly or indirectly from the full wages earned, other than permissible deductions as set forth in 29 CFR Part 3;

(3) That each laborer or mechanic has been paid not less than the applicable wage rates and fringe benefits or cash equivalents for the classification of work performed, as specified in the applicable wage determination incorporated into the contract.

(c) The weekly submission of a properly executed certification set forth on the reverse side of Optional Form WH-347 shall satisfy the requirement for submission of the "Statement of Compliance" required by subparagraph A.3.(ii)(b).

(d) The falsification of any of the above certifications may subject the contractor or subcontractor to civil or criminal prosecution under Section 1001 of Title 18 and Section 231 of Title 31 of the United States Code.

(iii) The contractor or subcontractor shall make the records required under subparagraph A.3.(f) available for inspection, copying, or transcription by authorized representatives of HUD or its designee or the Department of Labor, and shall permit such representatives to interview employees during working hours on the job. If the contractor or subcontractor fails to submit the required records or to make them available, HUD or its designee may, after written notice to the contractor, sponsor, applicant or owner, take such action as may be necessary to cause the suspension of any further payment, advance, or guarantee of funds. Furthermore, failure to submit the required records upon request or to make such records available may be grounds for debarment action pursuant to 29 CFR 5.12.

#### 4. Apprentices and Trainees.

(i) Apprentices. Apprentices will be permitted to work at less than the predetermined rate for the work they performed when they are employed pursuant to and individually registered in a bona fide apprenticeship program registered with the U.S. Department of Labor, Employment and Training Administration, Office of Apprenticeship Training, Employer and Labor Services, or with a State Apprenticeship Agency recognized by the Office, or if a person is employed in his or her first 90 days of probationary employment as an apprentice in such an apprenticeship program, who is not individually registered in the program, but who has been certified by the Office of Apprenticeship Training, Employer and Labor Services or a State Apprenticeship Agency (where appropriate) to be eligible for probationary employment as an apprentice. The allowable ratio of apprentices to journeymen on the job site in any craft classification shall not be greater than the ratio permitted to the contractor as to the entire work force under the registered program. Any worker listed on a payroll at an apprentice wage rate, who

is not registered or otherwise employed as stated above, shall be paid not less than the applicable wage rate on the wage determination for the classification of work actually performed. In addition, any apprentice performing work on the job site in excess of the ratio permitted under the registered program shall be paid not less than the applicable wage rate on the wage determination for the work actually performed. Where a contractor is performing construction on a project in a locality other than that in which its program is registered, the ratios and wage rates (expressed in percentages of the journeyman's hourly rate) specified in the contractor's or subcontractor's registered program shall be observed. Every apprentice must be paid at not less than the rate specified in the registered program for the apprentice's level of progress, expressed as a percentage of the journeyman hourly rate specified in the applicable wage determination. Apprentices shall be paid fringe benefits in accordance with the provisions of the apprenticeship program. If the apprenticeship program does not specify fringe benefits, apprentices must be paid the full amount of fringe benefits listed on the wage determination for the applicable classification. If the Administrator determines that a different practice prevails for the applicable apprentice classification, fringes shall be paid in accordance with that determination. In the event the Office of Apprenticeship Training, Employer and Labor Services, or a State Apprenticeship Agency recognized by the Office, withdraws approval of an apprenticeship program, the contractor will no longer be permitted to utilize apprentices at less than the applicable predetermined rate for the work performed until an acceptable program is approved.

(ii) Trainees. Except as provided in 29 CFR 5.16, trainees will not be permitted to work at less than the predetermined rate for the work performed unless they are employed pursuant to and individually registered in a program which has received prior approval, evidenced by formal certification by the U.S. Department of Labor, Employment and Training Administration. The ratio of trainees to journeymen on the job site shall not be greater than permitted under the plan approved by the Employment and Training Administration. Every trainee must be paid at not less than the rate specified in the approved program for the trainee's level of progress, expressed as a percentage of the journeyman hourly rate specified in the applicable wage determination. Trainees shall be paid fringe benefits in accordance with the provisions of the trainee program. If the trainee program does not mention fringe benefits, trainees shall be paid the full amount of fringe benefits listed on the wage determination unless the Administrator of the Wage and Hour Division determines that there is an apprenticeship program associated with the corresponding journeyman wage rate on the wage determination which provides for less than full fringe benefits for apprentices. Any employee listed on the payroll at a trainee rate who is not registered and participating in a training plan approved by

the Employment and Training Administration shall be paid not less than the applicable wage rate on the wage determination for the work actually performed. In addition, any trainee performing work on the job site in excess of the ratio permitted under the registered program shall be paid not less than the applicable wage rate on the wage determination for the work actually performed. In the event the Employment and Training Administration withdraws approval of a training program, the contractor will no longer be permitted to utilize trainees at less than the applicable predetermined rate for the work performed until an acceptable program is approved.

(iii) Equal employment opportunity. The utilization of apprentices, trainees and journeymen under 29 CFR Part 5 shall be in conformity with the equal employment opportunity requirements of Executive Order 11246, as amended, and 29 CFR Part 30.

5. Compliance with Copeland Act requirements. The contractor shall comply with the requirements of 29 CFR Part 3 which are incorporated by reference in this contract.

6. Subcontracts. The contractor or subcontractor will insert in any subcontracts the clauses contained in subparagraphs 1 through 11 in this paragraph A and such other clauses as HUD or its designee may by appropriate instructions require, and a copy of the applicable prevailing wage decision, and also a clause requiring the subcontractors to include these clauses in any lower tier subcontracts. The prime contractor shall be responsible for the compliance by any subcontractor or lower tier subcontractor with all the contract clauses in this paragraph.

7. Contract termination; debarment. A breach of the contract clauses in 29 CFR 5.5 may be grounds for termination of the contract and for debarment as a contractor and a subcontractor as provided in 29 CFR 5.12.

8. Compliance with Davis-Bacon and Related Act Requirements. All rulings and interpretations of the Davis-Bacon and Related Acts contained in 29 CFR Parts 1, 3, and 5 are herein incorporated by reference in this contract.

9. Disputes concerning labor standards. Disputes arising out of the labor standards provisions of this contract shall not be subject to the general disputes clause of this contract. Such disputes shall be resolved in accordance with the procedures of the Department of Labor set forth in 29 CFR Parts 5, 6, and 7. Disputes within the meaning of this clause include disputes between the contractor (or any of its subcontractors) and HUD or its designee, the U.S. Department of Labor, or the employees or their representatives.

10. (i) Certification of Eligibility. By entering into this contract the contractor certifies that neither it (nor he or she) nor any person or firm who has an interest in the contractor's firm is a person or firm ineligible to be awarded Government contracts by virtue of Section 3(a) of the Davis-Bacon Act or 29 CFR 5.12(a)(1) or to be

awarded HUD contracts or participate in HUD programs pursuant to 24 CFR Part 24.

(ii) No part of this contract shall be subcontracted to any person or firm ineligible for award of a Government contract by virtue of Section 3(a) of the Davis-Bacon Act or 29 CFR 5.12(a)(1) or to be awarded HUD contracts or participate in HUD programs pursuant to 24 CFR Part 24.

(iii) The penalty for making false statements is prescribed in the U.S. Criminal Code, 18 U.S.C. 1001. Additionally, U.S. Criminal Code, Section 1 01 0, Title 18, U.S.C., "Federal Housing Administration transactions", provides in part: "Whoever, for the purpose of . . . influencing in any way the action of such Administration . . . makes, utters or publishes any statement knowing the same to be false . . . shall be fined not more than \$5,000 or imprisoned not more than two years, or both."

11. Complaints, Proceedings, or Testimony by Employees. No laborer or mechanic to whom the wage, salary, or other labor standards provisions of this Contract are applicable shall be discharged or in any other manner discriminated against by the Contractor or any subcontractor because such employee has filed any complaint or instituted or caused to be instituted any proceeding or has testified or is about to testify in any proceeding under or relating to the labor standards applicable under this Contract to his employer.

B. Contract Work Hours and Safety Standards Act. The provisions of this paragraph B are applicable where the amount of the prime contract exceeds \$100,000. As used in this paragraph, the terms "laborers" and "mechanics" include watchmen and guards.

(1) Overtime requirements. No contractor or subcontractor contracting for any part of the contract work which may require or involve the employment of laborers or mechanics shall require or permit any such laborer or mechanic in any workweek in which the individual is employed on such work to work in excess of 40 hours in such workweek unless such laborer or mechanic receives compensation at a rate not less than one and one-half times the basic rate of pay for all hours worked in excess of 40 hours in such workweek.

(2) Violation; liability for unpaid wages; liquidated damages. In the event of any violation of the clause set forth in subparagraph (1) of this paragraph, the contractor and any subcontractor responsible therefor shall be liable for the unpaid wages. In addition, such contractor and subcontractor shall be liable to the United States (in the case of work done under contract for the District of Columbia or a territory, to such District or to such territory), for liquidated damages. Such liquidated damages shall be computed with respect to each individual laborer or mechanic, including watchmen and guards, employed in violation of the clause set forth in subparagraph (1) of this paragraph, in the sum of \$10 for each calendar day on which such individual was required or permitted to work in excess of the standard workweek of 40 hours without payment of the overtime wages required by the clause set forth in subparagraph (1) of this paragraph.

(3) **Withholding for unpaid wages and liquidated damages.** HUD or its designee shall upon its own action or upon written request of an authorized representative of the Department of Labor withhold or cease to be withheld, from any moneys payable on account of work performed by the contractor or subcontractor under any such contract or any other Federal contract with the same prime contract, or any other Federally-assisted contract subject to the Contract Work Hours and Safety Standards Act which is held by the same prime contractor such sums as may be determined to be necessary to satisfy any liabilities of such contractor or subcontractor for unpaid wages and liquidated damages as provided in the clause set forth in subparagraph (2) of this paragraph.

(4) **Subcontracts.** The contractor or subcontractor shall insert in any subcontracts the clauses set forth in subparagraph (1) through (4) of this paragraph and also a clause requiring the subcontractors to include these clauses in any lower tier subcontracts. The prime contractor shall be responsible for compliance by any subcontractor or lower tier subcontractor with the clauses set forth in subparagraphs (1) through (4) of this paragraph.

**C. Health and Safety.** The provisions of this paragraph C are applicable where the amount of the prime contract exceeds \$100,000.

(1) No laborer or mechanic shall be required to work in surroundings or under working conditions which are unsanitary, hazardous, or dangerous to his health and safety as determined under construction safety and health standards promulgated by the Secretary of Labor by regulation.

(2) The Contractor shall comply with all regulations issued by the Secretary of Labor pursuant to Title 29 Part 1926 and failure to comply may result in imposition of sanctions pursuant to the Contract Work Hours and Safety Standards Act, (Public Law 91-54, 83 Stat 96). 40 USC 3701 et seq.

(3) The contractor shall include the provisions of this paragraph in every subcontract so that such provisions will be binding on each subcontractor. The contractor shall take such action with respect to any subcontractor as the Secretary of Housing and Urban Development or the Secretary of Labor shall direct as a means of enforcing such provisions.



## ATTACHMENT #4

# Equal Employment Opportunity is THE LAW

### Employers Holding Federal Contracts or Subcontracts

Applicants to and employees of companies with a Federal government contract or subcontract are protected under the following Federal authorities:

### **RACE, COLOR, RELIGION, SEX, NATIONAL ORIGIN**

Executive Order 11246, as amended prohibits job discrimination on the basis of race, color, religion, sex or national origin, and requires affirmative action to ensure equality of opportunity in all aspects of employment.

### **INDIVIDUALS WITH DISABILITIES**

Section 503 of the Rehabilitation Act of 1973, as amended, prohibits job discrimination because of disability and requires affirmative action to employ and advance in employment qualified individuals with disabilities who, with reasonable accommodation, can perform the essential functions of a job.

### **VIETNAM ERA, SPECIAL DISABLED, RECENTLY SEPARATED, AND OTHER PROTECTED VETERANS**

The Vietnam Era Veterans Readjustment Assistance Act of 1974, as amended, 38 U.S.C. 4212, prohibits job discrimination and requires affirmative action to employ and advance in employment qualified Vietnam era veterans, qualified special disabled veterans, recently separated veterans, and other protected veterans. A recently separated veteran is any veteran during the three-year period beginning on the date of such veteran's discharge or release from active duty in the U.S. military, ground, naval or air service.

### **RETALIATION**

Retaliation is prohibited against a person who files a charge of discrimination, participates in an EEOC proceeding, or otherwise opposes discrimination under these Federal laws.

Any person who believes a contractor has violated its nondiscrimination or affirmative action obligation under the authorities above should contact immediately:

The Office of Federal Contract Compliance Programs (OFCCP), Employment Standards Administration, U.S. Department of Labor, 200 Constitution Avenue, N.W. Washington, DC 20210 (202) 693-0101 or call an OFCCP regional or district office listed in most telephone directories under U.S. Government, Department of Labor. For individuals with hearing impairment, OFCCP's TTY number is (202) 693-1337.

### Private Employment, State and Local Governments, Educational Institutions, Employment Agencies and Labor Organizations

Applicants to and employees of most private employers, state and local governments, educational institutions, employment agencies and labor organizations are protected under the following Federal laws:

### **RACE, COLOR, RELIGION, SEX, NATIONAL ORIGIN**

Title VII of the Civil Rights Act of 1964, as amended, prohibits discrimination in hiring, promotion, discharge, pay, fringe benefits, job training, classification, referral, and other aspects of employment, on the basis of race, color, religion, sex (including pregnancy and sexual harassment) or national origin. Religious discrimination includes failing to reasonably accommodate an employee's religious practices where the accommodation does not impose undue hardship.

### **DISABILITY**

Title I and Title V of the Americans with Disabilities Act of 1990 (ADA), as amended, protect qualified applicants and employees with disabilities from discrimination in hiring, promotion, discharge, pay, job training, fringe benefits, classification, referral, and other aspects of employment on the basis of disability.

The law also requires that covered entities provide qualified applicants and employees with disabilities with reasonable accommodations, unless such accommodations would impose an undue hardship on the employer.

### **AGE**

The Age Discrimination in Employment Act of 1967, as amended, protects applicants and employees 40 years of age or older from discrimination on the basis of age in hiring, promotion, discharge, compensation, terms, conditions or privileges of employment.

### **SEX (WAGES)**

In addition to sex discrimination prohibited by Title VII of the Civil Rights Act of 1964, as amended, the Equal Pay Act of 1963, as amended, prohibits sex discrimination in payment of wages to women and men

performing substantially equal work in jobs that require equal skill, effort and responsibility under similar working conditions, in the same establishment.

### **RETALIATION**

Retaliation is prohibited against a person who files a charge of discrimination, participates in a discrimination proceeding, or otherwise opposes discrimination under these Federal laws.

If you believe that you have been discriminated against under any of the above laws, and to ensure that you meet strict procedural timelines to preserve the ability of EEOC to investigate your complaint and to protect your right to file a private lawsuit, you should immediately contact:

The U.S. Equal Employment Opportunity Commission (EEOC), Washington, DC 20507 or an EEOC field office by calling toll free (1-800) 688-4000. For individuals with hearing impairments, EEOC's toll free TTY number is 1-800-800-8220.

### Programs or Activities Receiving Federal Financial Assistance

### **RACE, COLOR, SEX, NATIONAL ORIGIN**

In addition to the protection of Title VII of the Civil Rights Act of 1964, as amended, Title VI of the Civil Rights Act prohibits discrimination on the basis of race, color or national origin in programs or activities receiving Federal financial assistance. Employment discrimination is covered by Title VI if the primary objective of the financial assistance is provision of employment, or where employment discrimination causes or may cause discrimination in providing services under such programs.

Title IX of the Education Amendments of 1972 prohibits employment discrimination on the basis of sex in educational programs or activities which receive Federal assistance.

### **INDIVIDUALS WITH DISABILITIES**

Section 504 of the Rehabilitation Act of 1973, as amended, prohibits employment discrimination on the basis of disability in any program or activity which receives Federal financial assistance in the federal government, public or private agency. Discrimination is prohibited in all aspects of employment against persons with disabilities who with or without reasonable accommodation, can perform the essential functions of a job.

If you believe you have been discriminated against in a program of any institution which receives Federal assistance, you should contact immediately the Federal agency providing such assistance.

Publication (H) EOP 1420  
Revised August 2008



**EQUAL HOUSING  
OPPORTUNITY**

**We Do Business in Accordance With the Federal Fair  
Housing Law**

(The Fair Housing Amendments Act of 1988)

**It is illegal to Discriminate Against Any Person  
Because of Race, Color, Religion, Sex,  
Handicap, Familial Status, or National Origin**

- In the sale or rental of housing or residential lots
- In the provision of real estate brokerage services
- In advertising the sale or rental of housing
- In the appraisal of housing
- In the financing of housing
- Blockbusting is also illegal

Anyone who feels he or she has been discriminated against may file a complaint of housing discrimination:

1-800-669-9777 (Toll Free)  
1-800-927-9275 (TTY)

U.S. Department of Housing and  
Urban Development  
Assistant Secretary for Fair Housing and  
Equal Opportunity  
Washington, D.C. 20410

U.S. DEPARTMENT OF LABOR

EMPLOYMENT STANDARDS ADMINISTRATION

Wage and Hour Division  
Washington, D.C. 20210



# NOTICE

## EMPLOYEE POLYGRAPH PROTECTION ACT

The Employee Polygraph Protection Act prohibits most private employers from using lie detector tests either for pre-employment screening or during the course of employment.

### PROHIBITIONS

Employers are generally prohibited from requiring or requesting any employee or job applicant to take a lie detector test, and from discharging, disciplining, or discriminating against an employee or prospective employee for refusing to take a test or for exercising other rights under the Act.

### EXEMPTIONS\*

Federal, State and local governments are not affected by the law. Also, the law does not apply to tests given by the Federal Government to certain private individuals engaged in national security-related activities.

The Act permits polygraph (a kind of lie detector) tests to be administered in the private sector, subject to restrictions, to certain prospective employees of security service firms (armored car, alarm, and guard), and of pharmaceutical manufacturers, distributors and dispensers.

The Act also permits polygraph testing, subject to restrictions, of certain employees of private firms who are reasonably suspected of involvement in a workplace incident (theft, embezzlement, etc.) that resulted in economic loss to the employer.

### EXAMINEE RIGHTS

Where polygraph tests are permitted, they are subject to numerous strict standards concerning the conduct and length of the test. Examinees have a number of specific rights, including the right to a written notice before testing, the right to refuse or discontinue a test, and the right not to have test results disclosed to unauthorized persons.

### ENFORCEMENT

The Secretary of Labor may bring court actions to restrain violations and assess civil penalties up to \$10,000 against violators. Employees or job applicants may also bring their own court actions.

### ADDITIONAL INFORMATION

Additional information may be obtained, and complaints of violations may be filed, at local offices of the Wage and Hour Division. To locate your nearest Wage-Hour office, telephone our toll-free information and help line at 1-888-4USWAGE (1-888-487-9243). A customer service representative is available to assist you with referral information from 8am to 6pm in your time zone; or if you have access to the internet, you may log onto our Home page at [www.wagehour.dol.gov](http://www.wagehour.dol.gov).

**THE LAW REQUIRES EMPLOYERS TO DISPLAY THIS POSTER WHERE EMPLOYEES AND JOB APPLICANTS CAN READILY SEE IT.**

*\*The law does not preempt any provision of any State or local law or any collective bargaining agreement which is more restrictive with respect to lie detector tests.*

U.S. DEPARTMENT OF LABOR  
EMPLOYMENT STANDARDS ADMINISTRATION  
Wage and Hour Division  
Washington, D.C. 20210

WH Publication 1462  
June 2003

ATTACHMENT #5

## Section 3 Federal Requirements

### What is Section 3?

Section 3 is a provision that HUD requires from all project that are funded with federal grants/loans. Community Development Block Grant (CDBG) and HOME funds require that Section 3 provisions be followed.

All contractors/subcontractors who are awarded projects funded by CDBG and HOME funds must give preference to hiring Section 3 residents or business concerns residing in the metro-Milwaukee area.

All contractors/subcontractors who are awarded projects funded by CDBG and HOME funds must report to the City of West Allis whether they are a Business Concern by filling out the Section 3 Qualification Forms that are included in the bid contract book (see definition of "Business Concern" below).

### What is a "Section 3 resident"?

- (1) A low- or very low-income persons, or;
- (2) a public housing resident.

### What is "low- or very low-income"?

Households whose annual income (including assets and interest from bank accounts) is AT OR BELOW the following income limits pertaining to particular household sizes:

* 2014 figures	1 Person Household	2 Person Household	3 Person Household	4 Person Household	5 Person Household	6 Person Household	7 Person Household	8 Person Household
80% CMI	\$39,400	\$45,000	\$50,650	\$56,250	\$60,750	\$65,250	\$69,750	\$74,250

### What does "Business Concern" mean?

Businesses that can provide evidence that they meet one or the following:

- 1. 51% or more owned by Section 3 residents; or
- 2. At least 30% of its fulltime employees include persons that are currently Section 3 residents, or within 3 years of the date of first employment with the business concern, were Section 3 residents; or
- 3. Provides evidence, as required, or a commitment to subcontract in excess of 25% of the dollar award of all subcontracts to be awarded to business concerns that meet the qualifications in the above two paragraphs.

*\* If you would like assistance filling out the Section 3 forms or are not fully understanding what reporting is required of you, please contact Kristi Johnson at 414-302-8463.*

CONTRACTOR CERTIFICATE REGARDING EQUAL EMPLOYMENT OPPORTUNITY

"E.O. 11246 Certification"

Project Name: \_\_\_\_\_

Project #: \_\_\_\_\_

Prime Contractor: \_\_\_\_\_

INSTRUCTIONS

This certification is required pursuant to Executive Order 11246 (30 C.F.R. 12319-25). The implementing rules and regulations provide that any bidder or prospective contractor, or any of their proposed subcontractors, shall state as initial part of the bid or negotiations of the contract whether it has participated in any previous contract or subcontract subject to the equal opportunity clause; and, if so, whether it has filed all compliance reports due under applicable instructions.

Where the certification indicates that the bidder has not filed a compliance report due under applicable instructions, such bidder shall be required to submit a compliance report within seven calendar days after bid opening. No contract shall be awarded unless such report is submitted.

GENERAL CONTRACTOR/SUBCONTRACTOR'S CERTIFICATION

Contractor Information:

Company Name: \_\_\_\_\_

Address: \_\_\_\_\_

\_\_\_\_\_

\_\_\_\_\_

1. Contractor has participated in a previous contract or subcontract subject to the Equal Opportunity Clause.

\_\_\_\_\_ Yes      \_\_\_\_\_ No

2. Compliance reports were required to be filed in connection with such contract or subcontract.

\_\_\_\_\_ Yes      \_\_\_\_\_ No





City of West Allis  
Department of Development  
7525 W. Greenfield Ave.  
West Allis, WI 53214

Project Name/Address: \_\_\_\_\_

### ANTI-LOBBYING CERTIFICATE

*Certification for contracts, grants, loans and cooperative agreements funded with CDBG or HOME dollars*

The undersigned Contractor certifies, to the best of his/her knowledge and belief that:

1. No Federal appropriated funds have been paid or will be paid, by or on behalf of the undersigned, to any person for influencing or attempting to influence an officer or employee of an agency, a Member of Congress, an officer or employee of Congress, or an employee of a Member of Congress in connection with the awarding of any Federal contract, the making of any Federal grant, the making of any Federal loan, the entering into any cooperative agreement, and the extension, continuation, renewal, amendment, or modification of any Federal contract, grant, loan or cooperative agreement.
2. If any funds other than Federal appropriated funds have been paid or will be paid to any person for making lobbying contracts to an office or employee of any agency, a Member of Congress, and officer or employee of Congress, or an employee of a Member of Congress in connection with the Federal contract, grant, loan, or cooperative agreement, the undersigned shall complete and submit Standard Form – LLL, "Disclosure Form to Report Lobbying," in accordance with its instructions as amended by "Government wide Guidance for New Restrictions on Lobbying," 61 Fed. 1413 (1/19/96).
3. The undersigned shall require that the language of this certification be included in the award documents for all subawards at all tiers (including subcontracts, subgrants, and contracts under grants, loans, and cooperative agreements) and that all subrecipients shall certify and disclose accordingly.

This certification is a material representation of fact upon which reliance was placed when this transaction was made or entered into. Submission of this certification is a prerequisite for making or entering into this transaction imposed by 31 U.S.C. 1352 (as amended by the Lobbying Disclosure Act of 1995). Any person who fails to file the required certification shall be subject to civil penalty of not less than \$10,000 and not more than \$100,000 for each such failure.

Pursuant to 31 U.S.C. 1352(c)(1)-(2)(A), any person who makes a prohibited expenditure or fails to file or amend a required certification or disclosure form shall be subject to a civil penalty of not less than \$10,000 and not more than \$100,000 for each such failure.

The Contractor, \_\_\_\_\_, certifies or affirms the truthfulness and accuracy of each statement of its certification and disclosure, if any. In addition, the Contractor understands and agrees that the provisions of 31 U.S.C. A 3801 et seq., and 18 P.C.S. § 4904 (pertaining to unsworn falsification to authorities) apply to this certification and disclosure.

Company Name: \_\_\_\_\_

Company Officer: \_\_\_\_\_  
(Print Name and Title)

\_\_\_\_\_  
(Signature)

\_\_\_\_\_  
(Date)

**SECTION 3 COMPLIANCE REPORT**

Must be completed by every contractor or subcontractor awarded a construction contract on a Community Development Block Grant (CDBG) project.

Grantee: \_\_\_\_\_ Grant #: \_\_\_\_\_

Contractor: \_\_\_\_\_

Contract Amount: \$ \_\_\_\_\_

Indicate the efforts made to direct the employment and other economic opportunities generated by HUD financial assistance for housing and community development programs, to the greatest extent feasible, toward low and very low income persons, particularly those who are recipients of government assistance for housing. Check all that apply:

\_\_\_\_\_ Attempted to recruit low-income residents through local advertising media, signs prominently displayed at the project site, contracts with community organizations and public or private agencies operating within the metropolitan area or nonmetropolitan county in which the Section 3 covered program or project is located or similar methods.

\_\_\_\_\_ Participated in a HUD program or other program which promotes the training or employment of Section 3 residents.

\_\_\_\_\_ Participated in a HUD program or other program which promotes the award of contracts to business concerns which meet the definition of Section 3 business concerns.

\_\_\_\_\_ Coordinated with Youthbuild Programs administered in the metropolitan area in which the Section 3 covered project is located.

\_\_\_\_\_ Other. Describe: \_\_\_\_\_

Job Category	Staff		New Hires/Trainees Total # of new hires/trainees that are Section 3 residents	Total # staff hours for new hires that are Section 3 residents	Total staff hours for Section 3 employee
	Total # Employees	Total # Section 3 Employees			
Professional	_____	_____	_____	_____	_____
Technician	_____	_____	_____	_____	_____
Office/Clerical	_____	_____	_____	_____	_____
Construction:	_____	_____	_____	_____	_____
List by trade:	_____	_____	_____	_____	_____
_____	_____	_____	_____	_____	_____
_____	_____	_____	_____	_____	_____
_____	_____	_____	_____	_____	_____
_____	_____	_____	_____	_____	_____
_____	_____	_____	_____	_____	_____

**Submit to Grantee or Grantee's Representative prior to work beginning.**  
 Kristi Johnson  
 Department of Development  
 7525 W. Greenfield Ave.  
 West Allis, WI 53214





**Community Development Block Grant Program (CDBG)  
 Department of Development  
 City of West Allis, 7525 W. Greenfield Ave.  
 West Allis, WI 53214  
 414-302-8460**



**Section 3 Qualification for Contractor Businesses  
 And Minority Business Enterprise/Women Business Enterprise**

Please circle the most appropriate choice that best describes your Business Racial/Ethnic Code.

1. White Americans
2. Black Americans
3. Native Americans
4. Hispanic Americans
5. Asian/Pacific Americans
6. Hasidic Jews

**Business Representative  
 Fills Out Top Section**

What is your ethnicity? (Check only one box)       Hispanic       Non-Hispanic

Is your Business (51% or more) Owned by a Woman:       Yes       No

Type of Business :       Corporation       Partnership       Joint Venture       Sole Proprietorship

Your Contractor Tax Identification Number: \_\_\_\_\_

Your DUNS Number: \_\_\_\_\_

Business Name \_\_\_\_\_

Business Address \_\_\_\_\_

Individuals who meet the income limits set forth below can qualify as a Section 3 Business.

Find your household size in the left hand column. Determine if your **TOTAL** household income is either **EQUAL TO OR BELOW** the income range listed for your household size. You **DO NOT** need to indicate your income or household size on this form, merely check to see if you fall below, within or above the range listed for your household size and check the box yes or no listed below.

Household Size	Income Limit (2014 figures)
1	\$39,400
2	\$45,000
3	\$50,650
4	\$56,250
5	\$60,750
6	\$65,250
7	\$69,750
8	\$74,250

**Owners Fill Out  
 Bottom Section**

- Yes, I fall within or below the income range listed for my household size.
- No, my income is above the income range listed for my household size.
- I do not wish to provide this information.

I certify that this information is true and correct to the best of my knowledge.

Please Print Name \_\_\_\_\_

Signature \_\_\_\_\_ Date \_\_\_\_\_

**The information requested on this form regarding race and ethnicity status is needed to analyze and assure compliance with Federal Equal Opportunity laws and to meet the reporting requirements of those laws. Your cooperation in voluntarily giving this information is important to the success of our equal opportunity program.**



Community Development Block Grant Program (CDBG)  
 Department of Development  
 City of West Allis, 7525 W. Greenfield Ave.  
 West Allis, WI 53214  
 414-302-8460



**Section 3 Qualification for Contractor Businesses  
 And Minority Business Enterprise/Women Business Enterprise**

Please circle the most appropriate choice that best describes your Business Racial/Ethnic Code.

1. White Americans
2. Black Americans
3. Native Americans
4. Hispanic Americans
5. Asian/Pacific Americans
6. Hasidic Jews

**Business Representative  
 Fills Out Top Section**

What is your ethnicity? (Check only one box)       Hispanic       Non-Hispanic

Is your Business (51% or more) Owned by a Woman:       Yes       No

Type of Business :       Corporation       Partnership       Joint Venture       Sole Proprietorship

Your Contractor Tax Identification Number: \_\_\_\_\_

Your DUNS Number: \_\_\_\_\_

Business Name \_\_\_\_\_

Business Address \_\_\_\_\_

Individuals who meet the income limits set forth below can qualify as a Section 3 Business.

Find your household size in the left hand column. Determine if your **TOTAL** household income is either **EQUAL TO OR BELOW** the income range listed for your household size. You **DO NOT** need to indicate your income or household size on this form, merely check to see if you fall below, within or above the range listed for your household size and check the box yes or no listed below.

Household Size	Income Limit (2014 figures)
1	\$39,400
2	\$45,000
3	\$50,650
4	\$56,250
5	\$60,750
6	\$65,250
7	\$69,750
8	\$74,250

**Employees Fill Out  
 Bottom Section**

- Yes, I fall within or below the income range listed for my household size.
- No, my income is above the income range listed for my household size.
- I do not wish to provide this information.

I certify that this information is true and correct to the best of my knowledge.

Please Print Name \_\_\_\_\_

Signature \_\_\_\_\_

Date \_\_\_\_\_

The information requested on this form regarding race and ethnicity status is needed to analyze and assure compliance with Federal Equal Opportunity laws and to meet the reporting requirements of those laws. Your cooperation in voluntarily giving this information is important to the success of our equal opportunity program.



# NOTICE TO ALL EMPLOYEES

## Working on Federal or Federally Financed Construction Projects

### MINIMUM WAGES

You must be paid not less than the wage rate in the schedule posted with this Notice for the kind of work you perform.

### OVERTIME



You must be paid not less than one and one-half times your basic rate of pay for all hours worked over 40 a week. There are some exceptions.

### APPRENTICES

Apprentice rates apply only to apprentices properly registered under approved Federal or State apprenticeship programs.

### PROPER PAY

If you do not receive proper pay, contact the Contracting Officer listed below:

	
7925 West Greenfield Avenue West Allis, Wisconsin 53314 Phone 414/231-5400 Fax 414/231-5401	Department of Development 3127 Avenue of the Americas New York, NY 10013-2409

or you may contact the nearest office of the Wage and Hour Division, U.S. Department of Labor. The Wage and Hour Division has offices in several hundred communities throughout the country. They are listed in the U.S. Government section of most telephone directories under: **U.S. Department of Labor  
Employment Standards Administration**

U.S. Department of Labor  
Employment Standards  
Administration  
Wage and Hour Division



**Attachment #7**  
**WAGE DECISION**

General Decision Number: WI150001 06/26/2015 WI1

Superseded General Decision Number: WI20140001

State: Wisconsin

Construction Type: Building

Counties: Milwaukee, Ozaukee, Washington and Waukesha Counties in Wisconsin.

BUILDING CONSTRUCTION PROJECTS (Does not include residential construction consisting of single family homes and apartments up to and including 4 stories)

Note: Executive Order (EO) 13658 establishes an hourly minimum wage of \$10.10 for 2015 that applies to all contracts subject to the Davis-Bacon Act for which the solicitation is issued on or after January 1, 2015. If this contract is covered by the EO, the contractor must pay all workers in any classification listed on this wage determination at least \$10.10 (or the applicable wage rate listed on this wage determination, if it is higher) for all hours spent performing on the contract. The EO minimum wage rate will be adjusted annually. Additional information on contractor requirements and worker protections under the EO is available at [www.dol.gov/whd/govcontracts](http://www.dol.gov/whd/govcontracts).

Modification Number	Publication Date
0	01/02/2015
1	03/27/2015
2	05/15/2015
3	06/12/2015
4	06/26/2015

ASBE0205-001 06/01/2001

	Rates	Fringes
Asbestos Removal worker/hazardous material handler Includes preparation, wetting, stripping, removal, scrapping, vacuuming, bagging and disposing of all insulation materials from mechanical systems, whether they contain asbestos or not.....	\$ 17.90	4.45

BOIL0107-001 01/01/2013

	Rates	Fringes
BOILERMAKER Boilermaker.....	\$ 31.09	27.11

Small Boiler Repair (under  
25,000 lbs/hr).....\$ 26.91 16.00

-----  
BRWI0005-001 06/01/2013

	Rates	Fringes
TERRAZZO WORKER.....	\$ 30.71	16.78
TILE LAYER.....	\$ 29.71	16.78

-----  
BRWI0008-001 06/01/2013

	Rates	Fringes
BRICKLAYER.....	\$ 35.37	18.47

-----  
BRWI0008-003 06/01/2011

	Rates	Fringes
Marble Mason.....	\$ 35.58	16.07

-----  
CARP0264-001 06/01/2009

	Rates	Fringes
Carpenter & Soft Floor Layer (Including Acoustical work and Drywall hanging; Excluding Batt Insulation).....	\$ 31.38	16.03

-----  
CARP2337-002 06/01/2009

	Rates	Fringes
MILLWRIGHT.....	\$ 28.30	20.70

-----  
CARP2337-008 06/01/2009

	Rates	Fringes
PILEDRIVERMAN.....	\$ 28.11	21.08

-----  
ELEC0494-001 06/01/2014

	Rates	Fringes
ELECTRICIAN.....	\$ 33.93	22.67

-----  
\* ELEC0494-003 06/01/2015

	Rates	Fringes
Sound & Communications Installer.....	\$ 16.47	14.84
Technician.....	\$ 26.00	17.70

Installation, testing, maintenance, operation and servicing of  
all sound, intercom, telephone interconnect, closed circuit TV  
systems, radio systems, background music systems, language

laboratories, electronic carillon, antenna distribution systems, clock and program systems and low-voltage systems such as visual nurse call, audio/visual nurse call systems, doctors entrance register systems. Includes all wire and cable carrying audio, visual, data, light and radio frequency signals. Includes the installation of conduit, wiremold, or raceways in existing structures that have been occupied for six months or more where required for the protection of the wire or cable, but does not mean a complete conduit or raceway system. work covered does not include the installation of conduit, wiremold or any raceways in any new construction, or the installation of power supply outlets by means of which external electric power is supplied to any of the foregoing equipment or products

-----  
 ELEVO0015-001 01/01/2015

	Rates	Fringes
ELEVATOR MECHANIC.....	\$ 44.55	28.385

FOOTNOTE:

PAID VACATION: 8% of regular basic for employees with more than 5 years of service, and 6% for 6 months to 5 years of service.  
 PAID HOLIDAYS: New Years Day, Memorial Day, Independence Day, Labor Day, Veterans Day, Thanksgiving Day, Friday after Thanksgiving, and Christmas Day.

-----  
 ENGI0139-001 06/01/2015

KENOSHA, MILWAUKEE, OZAUKEE, RACINE, WASHINGTON, AND WAUKESHA COUNTIES

	Rates	Fringes
Power Equipment Operator		
Group 1.....	\$ 41.66	20.40
Group 2.....	\$ 41.16	20.40
Group 3.....	\$ 40.66	20.40
Group 4.....	\$ 39.97	20.40
Group 5.....	\$ 38.09	20.40
Group 6.....	\$ 32.94	20.40

HAZARDOUS WASTE PREMIUMS:

EPA Level "A" Protection: \$3.00 per hour  
 EPA Level "B" Protection: \$2.00 per hour  
 EPA Level "C" Protection: \$1.00 per hour

POWER EQUIPMENT OPERATORS CLASSIFICATIONS

GROUP 1: Cranes, Tower Cranes, Pedestal Tower Cranes and Derricks with or w/o attachments with a lifting capacity of over 100 tons; or Cranes, Tower Cranes, Pedestal Tower Cranes and Derricks with boom, leads, and/or jib lengths measuring 176 feet or longer; Self-Erecting Tower Cranes

over 4000 lbs lifting capacity; All Cranes with Boom Dollies; Boring Machines (directional); Master Mechanic. \$0.50 additional per hour per 100 tons or 100 ft of boom over 200 ft or lifting capacity of crane over 200 tons to a maximum of 300 tons or 300 ft. Thereafter an increase of \$0.01 per ft or ton, whichever is greater.

GROUP 2: Cranes, Tower Cranes, Pedestal Tower Cranes and Derricks with or without attachments with a lifting capacity of 100 tons or less; or Cranes, Tower Cranes Portable Tower Cranes, Pedestal Tower Cranes and Derricks with boom, leadsand/or jib lengths measuring 175 feet or less; Backhoes (excavators) 130,000 lbs and over; Caisson Rigs; Pile Drivers; Boring Machines (vertical or horizontal), Versi-Lift, Tri-Lift, Gantry 20,000 lbs & over.

GROUP 3: Backhoe (excavator) under 130,000 lbs; Self-erecting Tower Crane 4000 lbs & under lifting capacity; Traveling Crane (bridge type); Skid Rigs; Dredge Operator; Mechanic; Concrete Paver (over 27E); Concrete Spreader and Distributor; Forklift/ Telehandler (machinery- moving / steel erection); Hydro Blaster, 10,000 psi and over

GROUP 4: Material Hoists; Stack Hoists; Hydraulic Backhoe (tractor or truck mounted); Hydraulic Crane, 5 tons or under (tractor or truck mounted); Hoist (tuggers 5 tons & over); Hydro-Excavators/Daylighters; Concrete Pumps Rotec type Conveyors; Tractor/Bulldozer/End Loader (over 40 hp); Motor Patrol; Scraper Operator; Sideboom; Straddle Carrier; Welder; Bituminous Plant and Paver Operator; Roller over 5 tons; Rail Leveling Machine (Railroad); Tie Placer; Tie Extractor; Tie Tamper; Stone Leveler; Rotary Drill Operator and Blaster; Percussion Drill Operator; Air Track Drill and/or Hammers; Gantry (under 20,000 lbs); Tencher (wheel type or chain type having 8 inch or larger bucket); Milling Machine; Off-Road Material Haulers.

GROUP 5: Backfiller; Concrete Auto Breaker (large); Concrete Finishing Machines (road type); Rubber Tired Roller; Concrete Batch Hopper; Concrete Conveyor Systems; Grout Pumps; Concrete Mixers (14S or over); Screw Type Pumps and Gypsum Pumps; Tractor, Bulldozer, End Loader (under 40 hp); Trencher (chain type, bucket under 8 inch); Industrial Locomotives; Rollers under 5 tons; Stump Grinder/Chipper (Large); Timber Equipment; Firemen (pile drivers and derricks); Personnel Hoist, Telehandler over 8000 lbs; Robotic Tool Carrier with or without attachments

GROUP 6: Tampers - Compactors (riding type); Assistant Engineer; A-Frames and Winch Trucks; Concrete Auto Breaker; Hydrohammers (small); Brooms and Sweepers; Hoist (tuggers under 5 tons); Boats (Tug, Safety, Work Barges, Launch); Shouldering Machine Operator; Prestress Machines; Screed Operator; Stone Crushers and Screening Plants; Screed Operators (milling machine), Farm or Industrial Tractor Mounted Equipment; Post Hole Digger; Fireman (asphalt plants); Air Compressors over 400 CFM; Generators, over 150 KW; Augers (vertical and horizontal); Air, Electric, Hydraulic Jacks (slipform); Skid Steer Loaders (with or without attachments); Boiler Operators (temporary heat);



Refrigeration Plant/Freeze Machines; Power Pack  
 Vibratory/Ultra Sound Drivers and Extractors; Welding  
 Machines; Heaters (mechanical); Pumps; Winches (small  
 electric); Oiler and Greaser; Rotary Drill Tender;  
 Conveyor; Forklifts/Telehandler 8000 lbs & under;  
 Elevators: Automatic Hoists; Pumps (well points);  
 Combination Small Equipment Operators

\* IRON0008-005 06/01/2014

	Rates	Fringes
IRONWORKER.....	\$ 30.77	23.96

Paid Holidays: New Year's Day, Memorial Day, July 4th, Labor  
 Day, Thanksgiving Day & Christmas Day.

\* LABO0113-001 06/01/2015

	Rates	Fringes
LABORER		
(1) General Laborer (Including Plaster Tender) ..	\$ 29.76	17.74
(2) Air & Electric Equipment, Mortar Mixer, Scaffold Builder, Erector, and Swing Stage.....	\$ 29.87	17.74
(3) Jackhammer Operator, Gunnite Machine Man.....	\$ 29.98	17.74
(4) Caisson Worker - Topman.	\$ 30.07	17.74
(5) Construction Specialist.	\$ 30.23	17.74
(6) Nozzleman.....	\$ 30.27	17.74
(7) Caisson Work.....	\$ 30.42	17.74
(8) Barco Tamper.....	\$ 30.98	17.74

\* LABO0113-010 06/01/2015

	Rates	Fringes
Asbestos Laborer Asbestos Abatement [Preparation, removal, and encapsulation of hazardous materials from non- mechanical systems].....	\$ 29.76	17.74

PAIN0781-001 06/01/2013

	Rates	Fringes
Painters:		
(1) Brush, Roller.....	\$ 29.52	20.04
(2) Spray & Sandblast.....	\$ 30.27	20.04
(3) Drywall Taper/Finisher..	\$ 29.87	20.04

PAIN1204-002 06/01/2012

	Rates	Fringes
GLAZIER.....	\$ 34.19	18.25
-----		
PLAS0599-004 06/01/2013		
	Rates	Fringes
CEMENT MASON/CONCRETE FINISHER....	\$ 31.47	18.53
-----		
PLAS0599-005 06/01/2014		
	Rates	Fringes
PLASTERER.....	\$ 29.65	19.93
-----		
PLUM0075-001 06/01/2014		
	Rates	Fringes
PLUMBER (Including HVAC work)....	\$ 38.37	19.69
-----		
PLUM0601-001 01/01/2013		
	Rates	Fringes
PIPEFITTER (Including HVAC work).....	\$ 39.26	19.91
-----		
SFWI0183-001 01/01/2013		
	Rates	Fringes
SPRINKLER FITTER.....	\$ 38.50	21.03
-----		
SHEE0018-001 06/01/2011		
	Rates	Fringes
Sheet Metal Worker (Including HVAC duct work and Technicians).....	\$ 37.20	17.01
-----		
TEAM0662-003 05/01/2010		
	Rates	Fringes
TRUCK DRIVER		
1 & 2 Axles.....	\$ 25.09	15.20
3 or more Axles.....	\$ 25.24	15.20
-----		
SUWI2002-002 01/23/2002		
	Rates	Fringes
Asbestos Worker/Heat and Frost Insulator.....	\$ 25.36	8.37
Laborers:		
Concrete Worker.....	\$ 16.34	3.59

Landscape.....	\$ 8.73	8.40
ROOFER.....	\$ 18.01	3.28
Tile & Marble Finisher.....	\$ 13.89	7.43

---

WELDERS - Receive rate prescribed for craft performing operation to which welding is incidental.

---

Unlisted classifications needed for work not included within the scope of the classifications listed may be added after award only as provided in the labor standards contract clauses (29CFR 5.5 (a) (1) (ii)).

---

The body of each wage determination lists the classification and wage rates that have been found to be prevailing for the cited type(s) of construction in the area covered by the wage determination. The classifications are listed in alphabetical order of "identifiers" that indicate whether the particular rate is a union rate (current union negotiated rate for local), a survey rate (weighted average rate) or a union average rate (weighted union average rate).

#### Union Rate Identifiers

A four letter classification abbreviation identifier enclosed in dotted lines beginning with characters other than "SU" or "UAVG" denotes that the union classification and rate were prevailing for that classification in the survey. Example: PLUM0198-005 07/01/2014. PLUM is an abbreviation identifier of the union which prevailed in the survey for this classification, which in this example would be Plumbers. 0198 indicates the local union number or district council number where applicable, i.e., Plumbers Local 0198. The next number, 005 in the example, is an internal number used in processing the wage determination. 07/01/2014 is the effective date of the most current negotiated rate, which in this example is July 1, 2014.

Union prevailing wage rates are updated to reflect all rate changes in the collective bargaining agreement (CBA) governing this classification and rate.

#### Survey Rate Identifiers

Classifications listed under the "SU" identifier indicate that no one rate prevailed for this classification in the survey and the published rate is derived by computing a weighted average rate based on all the rates reported in the survey for that classification. As this weighted average rate includes all rates reported in the survey, it may include both union and non-union rates. Example: SULA2012-007 5/13/2014. SU indicates

the rates are survey rates based on a weighted average calculation of rates and are not majority rates. LA indicates the State of Louisiana. 2012 is the year of survey on which these classifications and rates are based. The next number, 007 in the example, is an internal number used in producing the wage determination. 5/13/2014 indicates the survey completion date for the classifications and rates under that identifier.

Survey wage rates are not updated and remain in effect until a new survey is conducted.

#### Union Average Rate Identifiers

Classification(s) listed under the UAVG identifier indicate that no single majority rate prevailed for those classifications; however, 100% of the data reported for the classifications was union data. EXAMPLE: UAVG-OH-0010 08/29/2014. UAVG indicates that the rate is a weighted union average rate. OH indicates the state. The next number, 0010 in the example, is an internal number used in producing the wage determination. 08/29/2014 indicates the survey completion date for the classifications and rates under that identifier.

A UAVG rate will be updated once a year, usually in January of each year, to reflect a weighted average of the current negotiated/CBA rate of the union locals from which the rate is based.

---

#### WAGE DETERMINATION APPEALS PROCESS

1.) Has there been an initial decision in the matter? This can be:

- \* an existing published wage determination
- \* a survey underlying a wage determination
- \* a Wage and Hour Division letter setting forth a position on a wage determination matter
- \* a conformance (additional classification and rate) ruling

On survey related matters, initial contact, including requests for summaries of surveys, should be with the Wage and Hour Regional Office for the area in which the survey was conducted because those Regional Offices have responsibility for the Davis-Bacon survey program. If the response from this initial contact is not satisfactory, then the process described in 2.) and 3.) should be followed.

With regard to any other matter not yet ripe for the formal process described here, initial contact should be with the Branch of Construction Wage Determinations. Write to:

Branch of Construction Wage Determinations  
Wage and Hour Division  
U.S. Department of Labor  
200 Constitution Avenue, N.W.  
Washington, DC 20210

2.) If the answer to the question in 1.) is yes, then an interested party (those affected by the action) can request review and reconsideration from the Wage and Hour Administrator (See 29 CFR Part 1.8 and 29 CFR Part 7). Write to:

Wage and Hour Administrator  
U.S. Department of Labor  
200 Constitution Avenue, N.W.  
Washington, DC 20210

The request should be accompanied by a full statement of the interested party's position and by any information (wage payment data, project description, area practice material, etc.) that the requestor considers relevant to the issue.

3.) If the decision of the Administrator is not favorable, an interested party may appeal directly to the Administrative Review Board (formerly the Wage Appeals Board). Write to:

Administrative Review Board  
U.S. Department of Labor  
200 Constitution Avenue, N.W.  
Washington, DC 20210

4.) All decisions by the Administrative Review Board are final.

=====  
END OF GENERAL DECISION