



City of West Allis

Meeting Agenda

Plan Commission

7525 W. Greenfield Ave.
West Allis, WI 53214

Wednesday, January 26, 2022

6:00 PM

City Hall - Virtual 7525 W Greenfield Ave.

REGULAR MEETING

*To reduce health risks associated with the COVID-19 virus, we are encouraging the Public to monitor the Plan Commission meeting remotely using the following Live Stream option:
<https://www.youtube.com/user/westalliscitychannel/live>*

Plan Commissioners and Applicants will receive further instructions on accessing a virtual Zoom meeting to organize a quorum and to participate in the meeting's agenda items.

A. CALL TO ORDER

B. ROLL CALL

C. APPROVAL OF MINUTES

1. [22-0011](#) December 1, 2021 Draft Minutes

Attachments: [December 1, 2021 Draft Minutes](#)

D. NEW AND PREVIOUS MATTERS

- 2A. [22-0012](#) Special Use Permit for a restaurant use to be located at 7629 W. Greenfield Ave.

Attachments: [\(SUP-SLA\) 7629 W Greenfield Ave Ethiopian Coffee Shop](#)

- 2B. [22-0013](#) Site, Landscaping, and Architectural Plans for Ethiopian Coffee Shop, a proposed cafe to be located at 7629 W. Greenfield Ave. submitted by Amina Bell. (Tax Key 452-0026-000)

Attachments: [\(SUP-SLA\) 7629 W Greenfield Ave Ethiopian Coffee Shop](#)

3. [22-0014](#) Site, Landscaping, and Architectural Plans for a proposed professional office use to be located at 11548 W. Theo Trecker Way, submitted by Mark A. Molinaro Jr. (Tax Key 414-9992-017)

Attachments: [\(SLA\) 11548 W TheoTrecker Way](#)

4. [22-0015](#) Right of Way vacation, 29** S. Waukesha Rd. submitted by David Schneck and Joan Sternweis. (abutting Tax Keys 521-9948-000, 521-9947-003 & 521-9947-005)

Attachments: [\(VAC\) ROW - 29** S Waukesha Rd](#)

5. [O-2022-0024](#) Ordinance to repeal and recreate the City Zoning Code.

Sponsors: Safety and Development Committee

Attachments: [\(ORD\) City Zoning Code](#)

6. [22-0016](#) 2021 Planning & Zoning Annual Report

Attachments: [2021 Annual Report](#)

E. ADJOURNMENT



All meetings of the Plan Commission are public meetings. In order for the general public to make comments at the committee meetings, the individual(s) must be scheduled (as an appearance) with the chair of the committee or the appropriate staff contact; otherwise, the meeting of the committee is a working session for the committee itself, and discussion by those in attendance is limited to committee members, the mayor, other alderpersons, staff and others that may be a party to the matter being discussed.

NOTICE OF POSSIBLE QUORUM

It is possible that members of, and possibly a quorum of, members of other governmental bodies of the municipality may be in attendance at the above-stated meeting to gather information. No action will be taken by any governmental body at the above-stated meeting other than the governmental body specifically referred to above in this notice.

NON-DISCRIMINATION STATEMENT

The City of West Allis does not discriminate against individuals on the basis of race, color, religion, age, marital or veterans' status, sex, national origin, disability or any other legally protected status in the admission or access to, or treatment or employment in, its services, programs or activities.

AMERICANS WITH DISABILITIES ACT NOTICE

Upon reasonable notice the City will furnish appropriate auxiliary aids and services when necessary to afford individuals with disabilities an equal opportunity to participate in and to enjoy the benefits of a service, program or activity provided by the City.

LIMITED ENGLISH PROFICIENCY STATEMENT

It is the policy of the City of West Allis to provide language access services to populations of persons with Limited English Proficiency (LEP) who are eligible to be served or likely to be directly affected by our programs. Such services will be focused on providing meaningful access to our programs, services and/or benefits.



City of West Allis

Meeting Minutes

Plan Commission

7525 W. Greenfield Ave.
West Allis, WI 53214

Wednesday, December 1, 2021

6:00 PM

City Hall, Art Gallery
7525 W. Greenfield Ave.

REGULAR MEETING (draft minutes)

A. CALL TO ORDER

B. ROLL CALL

Present 5 - Wayne Clark, Rossi Manka, Amanda Nowak, David Raschka, and Dan Devine
Excused 5 - Kathleen Dagenhardt, Brian Frank, Eric Torkelson, Ben Holt, and Jessica Katzenmeyer

Others Attending

Jim Hoerig, Steve Ketterhagen., Billy Alfahel, Don Kurkowski, Joel Hoecherl, Anel Molina (via Zoom), Jacob Yahne (via Zoom), Corbin Miller (via Zoom)

Staff

Steve Schaer, AICP, Manager of Planning and Zoning
Tony Giron, AICP, Planner
Zac Roder, Planner

C. APPROVAL OF MINUTES

1. [21-0598](#) October 27, 2021 Draft Minutes

Attachments: [October 27, 2021 Draft Minutes](#)

Clark moved, seconded by Nowak to Approved this matter, motion carried.

D. NEW AND PREVIOUS MATTERS

- 2A. [21-0588](#) Special Use Permit for an automotive repair use to be located at 1230 S. 60 St.

Attachments: [\(SUP-SLA\) Magic Auto Repairs - 1230 S 60 St](#)

Raschka moved, seconded by Nowak to Approved all the actions on items 2A & 2B, motion carried on a consent vote.

- 2B. [21-0589](#) Site, Landscaping, and Architectural Plans for Magic Auto Repairs, a proposed automobile repair shop to be located at 1230 S. 60 St. submitted by Domingo Herrera d/b/a Magic Auto Repairs LLC. (Tax Key 438-0283-001)

Attachments: [\(SUP-SLA\) Magic Auto Repairs - 1230 S 60 St](#)

Items 2A & 2B were taken together.

Zac Roder presented.

Recommendation: Approve the Site, Landscaping and Architectural Plans for Magic Auto Repairs, a proposed automobile repair shop to be located at 1230 S. 60 St. submitted by Domingo Herrera d/b/a Magic Auto Repairs LLC. (Tax Key 438-0283-001) subject to the following conditions:

(Items 1-2 are required to be satisfied prior to the issuance of building permits associated with the proposed work reviewed by Plan Commission. Contractors applying for permits should be advised accordingly.)

1. Common Council approval of the Special use (scheduled for December 14, 2021). Applicant's acknowledgement signature on the Special Use Resolution. Revised Site, Landscaping, and Architectural Plans being submitted to and approved by the Planning & Zoning program to show the following: a) details (height and type) of the new perimeter fence around the site; b) a gate closure being added along W. Madison St.; c) refuse location and details added to site plan; d) construction schedule being provided to indicate start and completion dates of site improvements; e) exterior gates being closed after business hours; f) overhead doors being closed during business operations; g) any outdoor storage being indicated on plans and noted on plan to not exceed fence height. Contact Zac Roder, City Planner at 414-302-8465 with any questions.
2. Exterior lighting plans being submitted to the Planning and Zoning Office for approval. Lighting shall be directed downward and shall not extend beyond the limits of the property.

Raschka moved, seconded by Nowak to Approved all the actions on items 2A & 2B, motion carried on a consent vote.

Passed The Block Vote

Raschka moved, seconded by Nowak to Approved all the actions on items 2A & 2B, motion carried on a consent vote.

3. [21-0590](#) Site, Landscaping, and Architectural Plans for Alfahel Strip Mall, a proposed shopping center to be located at 3411 S. 108 St. submitted by Donald Kurkowski d/b/a Alfahel Strip Mall. (Tax Key 523-9951-002)

Attachments: [\(SLA\) Alfahel Strip Mall - 3411 S 108 St](#)

Zac Roder presented.

Rossi Manka asked staff to review paint on the exterior of the building and to ensure that it was in good condition.

Recommendation: Approve the Site, Landscaping and Architectural Plans for Alfahel Strip Mall, a proposed shopping center to be located at 3411 S. 108 St. submitted by Donald Kurkowski on behalf of Billy Alfahel d/b/a Alfahel Strip Mall. (Tax Key 523-9951-002) subject to the following conditions:

(Items 1 through 4 are required to be satisfied prior to the issuance of building permits associated with the proposed work reviewed by Plan Commission. Contractors applying

for permits should be advised accordingly.)

1. Revised Site, Landscaping, and Architectural Plans being submitted to and approved by the Planning & Zoning program to show the following: a) color samples; b) a landscaping plan to include species list (type, quantity, size) subject to approval of City Forestry; c) details of exterior lighting and/or a photometric plan being submitted for approval. Contact Zac Roder, at 414-302-8465 with any questions.
2. Documentation and approval showing compliance with the City of West Allis Stormwater Management Ordinance, to be submitted to the Building Inspections and Neighborhood Services Department by a registered Civil Engineer. A stormwater permit must be obtained from the City.
3. An estimated cost of paving, landscaping, and screening being submitted to the Department of Development for approval. Contact Zac Roder, City Planner at 414-302-8465.
4. A surety bond or other form of security as required under Sec. 12.13(14) of the Revised Municipal Code in the amount of 125% of landscaping and screening shall be executed by the applicant prior to the issuing of a building permit. Contact Zac Roder, City Planner at 414-302-8465.

Clark moved, seconded by Nowak to Approved this matter, motion carried.

4. [21-0591](#)

Site, Landscaping, and Architectural Plans for Cleveland Liquor, an existing liquor store located at 9131 W. Cleveland Ave. submitted by Hemant Khultan d/b/a Cleveland Liquor. (Tax Key 517-0184-000)

Attachments: [\(SLA\) Cleveland Liquor - 9131 W Cleveland Ave](#)

Tony Giron presented.

Recommendation: Approve the Site, Landscaping, and Architectural Plans for Cleveland Liquor, an existing liquor store located at 9131 W. Cleveland Ave. submitted by Hemant Khultan d/b/a Cleveland Liquor. (Tax Key 517-0184-000), subject to the following conditions:

(Item 1 is required to be satisfied prior to the issuance of building permits associated with the proposed work reviewed by Plan Commission. Contractors applying for permits should be advised accordingly.)

1. Revised Site, Landscaping, and Architectural Plans being submitted to the Planning & Zoning program to show the following: (a) a four-sided refuse enclosure and location within property boundaries; (b) repair of the damaged retaining wall; (c) removal of remnant signage from previous tenant; and (d) ADA ramp footings the same depth as basement footings. Contact Tony Giron, Planner for any questions at 414-302-8469.
2. A Major Privilege of Encroachment being submitted for proposed ADA ramp. Contact Tony Giron, City Planner at 414-302-8469.

(Remaining conditions of approval to be satisfied by the property owner within one year of Plan Commission approval)

3. *Right-of-way vacation being applied for or sponsored to discontinue a portion of right-of-way.*
4. *Compliance with Section 2814 of the City's Policy and Procedures Manual relative to that policy as it relates to the replacement and repair to City walkways of damaged or defective (if any) abutting sidewalk.*

Clark moved, seconded by Manka to Approved this matter, motion carried.

5. [21-0592](#)

Site, landscaping, and architectural plans for proposed assembly event venue to the existing mixed-use building located at 7035-37 W. Greenfield Ave. submitted by Jim Hoerig, Architects Planners, on behalf of Anel Molina, property owner/manager (Tax Key No. 453-0039-000).

Attachments: [\(SLA\) Molina Building - 7035-37 W Greenfield Ave](#)

Steve Schaer presented.

Recommendation: *Approval of the Site, landscaping, and architectural plans for proposed assembly event venue to the existing mixed-use building located at 7035-37 W. Greenfield Ave. submitted by Jim Hoerig, Architects Planners, on behalf of Anel Molina, property owner/manager (Tax Key No. 453-0039-000), subject to the following conditions:*

(Items 1 are required to be satisfied prior to the issuance of building permits associated with the proposed work reviewed by Plan Commission. Contractors applying for permits should be advised accordingly.)

1. *Revised Site, Landscaping, Screening and Architectural Plans being submitted to and approved by the Department of Development to show the following: (a) an alternate exterior material to brick veneer being considered for the faced base material; (b) avoid covering original fluted concrete columns on the NE and NW corners of the building façade. Contact Steve Schaer at 414-302-8460 with further questions.*

Nowak moved, seconded by Raschka to Approved this matter, motion carried.

6. [21-0593](#)

Site, Landscaping, and Architectural Plans for a proposed demolition of Motor Castings, a vacant foundry, located at 1323 S. 65 St. and 6500 W. Washington St. submitted by Jacob Yahne of Dalton Corporation/Motor Castings and Corbin Miller, Miller Recycling, LLC. (Tax Key No. 439-0139-002 and 439-0001-037)

Attachments: [\(SLA\) Motor Castings Demolition - 1323 S 65 St & 6500 W Washington St](#)

Steve Schaer presented.

Recommendation: *Recommend approval of the Site, Landscaping, and Architectural Plans for the Site, Landscaping, and Architectural Plans for a proposed demolition of Motor Castings, a vacant foundry, located at 1323 S. 65 St. submitted by Jacob Yahne*

of Dalton Corporation/Motor Castings and Corbin Miller, Miller Recycling, LLC. (Tax Key No. 439-0139-002)

(Items 1 through 5 are required to be satisfied prior to any work being done that is associated with the proposal reviewed by Plan Commission. Contractors applying for permits should be advised accordingly.)

1. Revised Site and Landscaping Plans being submitted to the Department of Development to show the following: (a) erosion control and post demo finished grading, drainage and landscaping plans being submitted; (b) specific site details with respect to locations of existing and proposed fencing on site (including any repair, removal and replacement) include details on site plan; (c) site plan to show extent of building and pavement removal on both sites and extent of grass ground cover (d) site plan to show driveway closures along S. 65 St. Contact Steven Schaer, Manager of Planning and Zoning at (414) 302-8466 with questions.
2. An estimated cost of landscaping and parking lot improvements being submitted to the Planning and Zoning Office for approval. Contact Steven Schaer, Manager of Planning and Zoning at (414) 302-8466 with questions.
3. A surety bond or other form of security as required under Sec. 12.13(14) of the Revised Municipal Code in the amount of 125% of the estimated cost of the demo and site landscaping improvements be executed by the applicant prior to the issuing of a building permit. Contact Steven Schaer, Manager of Planning and Zoning at (414) 302-8466 with questions.
4. Secure plumbing permits for all of the laterals and water services entering the property prior to beginning demo. The Laterals and water services will need to be abandoned and properly sealed before the actual building demo starts. Contact Mike Romens, City Plumbing inspector at (414) 302-8413.
5. Driveway permits being applied for with City Engineering for closure of existing driveways along S. 65 St. Contact Greg Bartelme, City Engineering (414) 302-8367.
6. Compliance with RMC 13.22(11) Rodent abatement including a report from a licensed pest control company stating that the premises was inspected and or treated and found to be rodent free. Contact Health Department Environmentalist (414) 302-8600.

(Remaining conditions of approval to be satisfied by the property owner within one year of Plan Commission approval)

7. Compliance with Section 2814 of the City's Policy and Procedures Manual relative to that policy as it relates to the replacement and repair to City walkways of damaged or defective (if any) abutting sidewalk.

Clark moved, seconded by Nowak to Approved this matter, motion carried.

7. [21-0594](#)

Site, Landscaping, and Architectural Plan amendment for JD's Pub, an existing tavern located at 6300 W. Lincoln Ave. submitted by Joel Hoercherl d/b/a JD's Pub. (Tax Key 475-0444-000)

Attachments: [\(SLA\) JD's Pub - 6300 W Lincoln Ave](#)

Tony Giron presented.

Recommendation: Approve the Site, Landscaping, and Architectural Plan amendment for JD's Pub, an existing tavern located at 6300 W. Lincoln Ave. submitted by Joel Hoercherl d/b/a JD's Pub. (Tax Key 475-0444-000), subject to the following conditions:

1. Revised Site, Landscaping, and Architectural Plans being submitted to the Planning & Zoning program to show the following: (a) removal of the 16x20 structure that has been razed; (b) addition of the gas fire pit. Contact Tony Giron, Planner at 414-302-8469 with any questions.
2. Apply for a demolition permit for the razing of the 16'x20' structure at the rear of the property. Contact Tony Giron, Planner at 414-302-8469 with any questions.

Clark moved, seconded by Nowak to Approved this matter, motion carried.

8. [21-0595](#) Certified Survey Map to combine two existing parcels located at 7020 W. National Ave. and 15** S. 71 St. into one parcel, submitted by Max Meinerz. (Tax Key Nos. 453-0272-001 and 453-0270-001)

Attachments: [\(CSM\) Max Meinerz - 7020 W National Ave & 15** S 71 St](#)

Tony Giron presented.

David Raschka abstained from voting.

Recommendation: Recommend Common Council approval of the Certified Survey Map to combine two existing parcels located at 7020 W. National Ave. and 15** S. 71 St. into one parcel, submitted by Max Meinerz. (Tax Key Nos. 453-0272-001 and 453-0270-001), Contact Tony Giron. At 414-302-8469 with any questions.

Manka motioned, seconded by Clark, Approve this matter, motion carried by the following vote:

Aye: 3 - Clark, Manka, and Nowak

No: 0

Abstain: 1 - Raschka

9. [21-0596](#) Signage Plan for Ope! Brewing, a proposed brewery, to be located at 6751 W. National Ave., submitted by Tina Lewis, d/b/a Ope! Brewing. (Tax Key No. 454-0251-001)

Attachments: [\(SIGN\) Ope! Brewing - 6751 W National Ave](#)

Tony Giron presented.

Recommendation: Recommend approval of the Signage Plan for Ope! Brewing, a proposed brewery, to be located at 6751 W. National Ave., submitted by Tina Lewis, d/b/a Ope! Brewing. (Tax Key No. 454-0251-001)

Clark moved, seconded by Raschka to Approved this matter, motion carried.

10. [21-0597](#) Overview of draft Zoning Ordinance update.

Zac Roder presented.

This matter was Discussed.

E. ADJOURNMENT

There being no other business, a motion was made by Wayne Clark and seconded by Dave Raschka to adjourn the Plan Commission meeting at 7:17 p.m.

The motion carried unanimously



All meetings of the {bdName} are public meetings. In order for the general public to make comments at the committee meetings, the individual(s) must be scheduled (as an appearance) with the chair of the committee or the appropriate staff contact; otherwise, the meeting of the committee is a working session for the committee itself, and discussion by those in attendance is limited to committee members, the mayor, other alderpersons, staff and others that may be a party to the matter being discussed.

NON-DISCRIMINATION STATEMENT

The City of West Allis does not discriminate against individuals on the basis of race, color, religion, age, marital or veterans' status, sex, national origin, disability or any other legally protected status in the admission or access to, or treatment or employment in, its services, programs or activities.

AMERICANS WITH DISABILITIES ACT NOTICE

Upon reasonable notice the City will furnish appropriate auxiliary aids and services when necessary to afford individuals with disabilities an equal opportunity to participate in and to enjoy the benefits of a service, program or activity provided by the City.

LIMITED ENGLISH PROFICIENCY STATEMENT

It is the policy of the City of West Allis to provide language access services to populations of persons with Limited English Proficiency (LEP) who are eligible to be served or likely to be directly affected by our programs. Such services will be focused on providing meaningful access to our programs, services and/or benefits.



STAFF REPORT
WEST ALLIS PLAN COMMISSION
Wednesday, January 26, 2022
6:00 PM
City Hall – Room 128

Watch: <https://www.youtube.com/user/westalliscitychannel>

- 2A. **Special Use Permit for a restaurant use to be located at 7629 W. Greenfield Ave.**
- 2B. **Site, Landscaping, and Architectural Plans for Ethiopian Coffee Shop, a proposed cafe to be located at 7629 W. Greenfield Ave., submitted by Amina Bell. (Tax Key 452-0026-000)**

Overview and Zoning

The property is owned by Audi Investments (Mr. Omer Audi), who will lease to a business that is proposing to remodel the former [Schroeder Books](#) (978 sq. ft.) [space](#) at 7629 W. Greenfield Ave. for a coffee shop.

The applicants, Thomas and Amina Bell, are proposing to open a new coffee shop specializing in Ethiopian style coffee. Coffee from Ethiopia is known for its bright fruited and floral flavors. These coffees typically have a light to medium body and complex flavor notes.

The applicant is proposing to conduct several improvements to the interior of the building with an estimated cost of \$20,000. The front of the shop will feature seating for customers and the rear will be remodeled for a prep kitchen (non-bake food items). Menu items will various coffee drinks, teas as well as pastries, soup, salads, cold sandwiches, fruit and healthy snacks available for dine-in or carry-out. If approved, the remodel work would commence in March or April of this year.

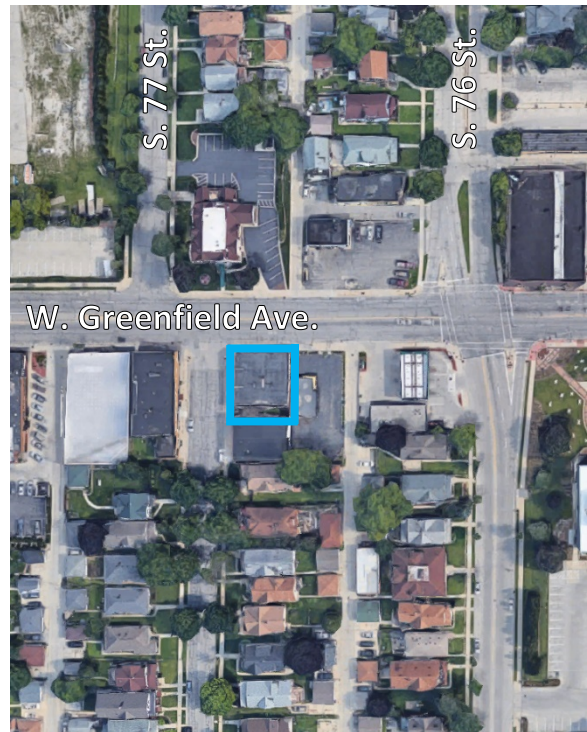



The business is a commercial use and is considered a restaurant/café that requires a special use in the C-2, Neighborhood Commercial District.

Hours of operation will be:

Monday – Saturday 6:00 am – 4:00 pm

Sunday 6:00 am – 2:00 pm

The building occupies most of the property, but there is a small and narrow 10-ft wide yard area behind the building used for access and some separation from the adjacent property (warehouse) to the south. The applicants haven't indicated if any outdoor seating would be provided. If so, it could likely be placed within City right-of-way (example along north or west side the building), or behind the building if space and accessibility permit.

W. Greenfield Ave.

S. 77 St.

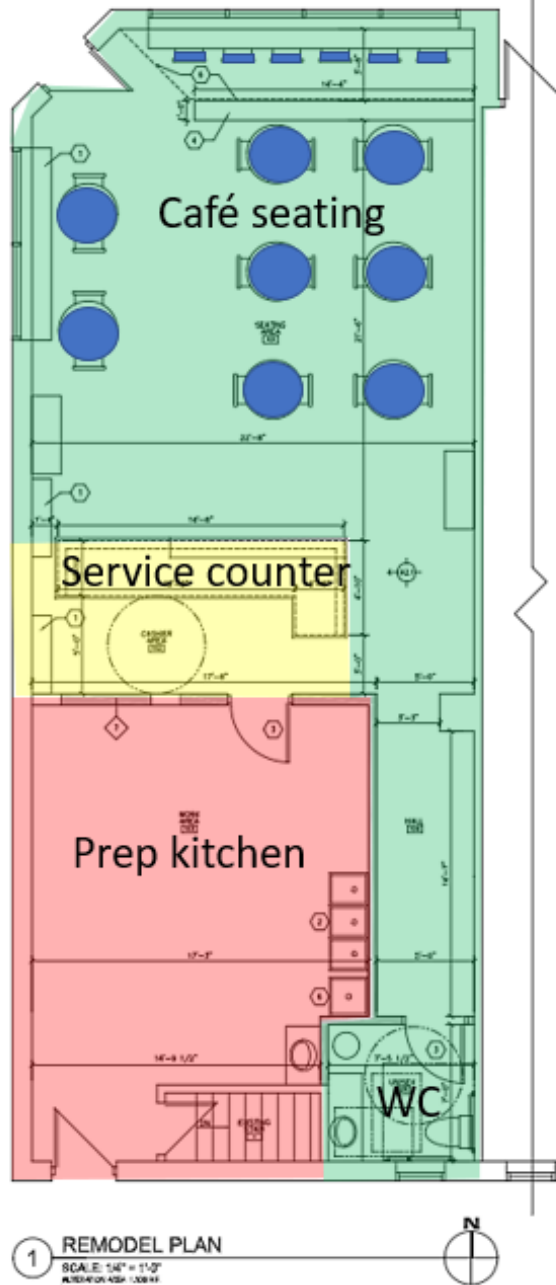

Floor Plan

The building interior will undergo alterations to suit the layout to the coffee shop's needs. The front portion of the shop area will be designated for customer seating; an existing window display platform (along the storefront windows) will be removed to allow additional counter seating along the front windows.

A retail service counter will be placed in the middle of the space. The back end will be used as a prep area for coffee and non-bake food items.

The alteration will provide public access via hallway to a remodeled, ADA compliant bathroom.

Site and Landscaping Plan

The property is nearly entirely built-out; no significant site and landscaping changes are proposed. Of note, staff will be reviewing the feasibility of relocating the dumpster(s) placement between the buildings. The dumpster is currently situated with City right-of-way along S. 77 St. There is a slight grade difference behind the building and the rear yards area is slightly lower than the adjacent city sidewalk. It appears that a platform was built years ago on private property for purpose of supporting a refuse container.

A surety requirement is not recommended by staff.



Architecture and signage

There are no proposed exterior alterations. Signage improvements will require a sign permit and may be approved administratively if the proposed signage meets the sign ordinance. General sign ordinance guidelines: [Sign-Handout-1-2-tenants \(westalliswi.gov\)](http://westalliswi.gov).

Recommendation: Common Council approval of the Special Use Permit for a restaurant use to be located at 7629 W. Greenfield Ave. and approval of the Site, Landscaping and Architectural Plans for Ethiopian Coffee Shop, a proposed cafe to be located at 7629 W. Greenfield Ave., submitted by Amina Bell. (Tax Key 452-0026-000), subject to the following:.

1. A revised site plan being submitted to the Planning and Zoning office: (a) specify general overall scope of improvements to the rear yard of the property, specifically refuse location, removal of remnant chain-link fence and clean-up/removal of weeds, graffiti and dead tree; (b) maintain access way to rear ingress/egress tenant doors.
2. Common Council approval of the special use. A public hearing before the Common Council is expect to be scheduled for February 17 at 6pm.



STAFF REPORT
WEST ALLIS PLAN COMMISSION
Wednesday, January 26, 2022
6:00 PM
City Hall – Room 128

Watch: <https://www.youtube.com/user/westalliscitychannel>

- 2A. **Special Use Permit for a restaurant use to be located at 7629 W. Greenfield Ave.**
- 2B. **Site, Landscaping, and Architectural Plans for Ethiopian Coffee Shop, a proposed cafe to be located at 7629 W. Greenfield Ave., submitted by Amina Bell. (Tax Key 452-0026-000)**

Overview and Zoning

The property is owned by Audi Investments (Mr. Omer Audi), who will lease to a business that is proposing to remodel the former [Schroeder Books](#) (978 sq. ft.) [space](#) at 7629 W. Greenfield Ave. for a coffee shop.

The applicants, Thomas and Amina Bell, are proposing to open a new coffee shop specializing in Ethiopian style coffee. Coffee from Ethiopia is known for its bright fruited and floral flavors. These coffees typically have a light to medium body and complex flavor notes.

The applicant is proposing to conduct several improvements to the interior of the building with an estimated cost of \$20,000. The front of the shop will feature seating for customers and the rear will be remodeled for a prep kitchen (non-bake food items). Menu items will various coffee drinks, teas as well as pastries, soup, salads, cold sandwiches, fruit and healthy snacks available for dine-in or carry-out. If approved, the remodel work would commence in March or April of this year.

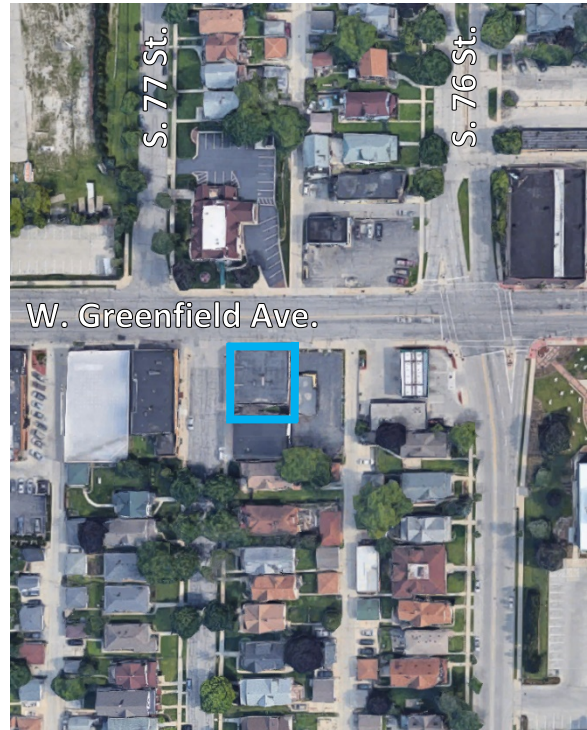



The business is a commercial use and is considered a restaurant/café that requires a special use in the C-2, Neighborhood Commercial District.

Hours of operation will be:

Monday – Saturday 6:00 am – 4:00 pm

Sunday 6:00 am – 2:00 pm

The building occupies most of the property, but there is a small and narrow 10-ft wide yard area behind the building used for access and some separation from the adjacent property (warehouse) to the south. The applicants haven't indicated if any outdoor seating would be provided. If so, it could likely be placed within City right-of-way (example along north or west side the building), or behind the building if space and accessibility permit.

W. Greenfield Ave.

S. 77 St.

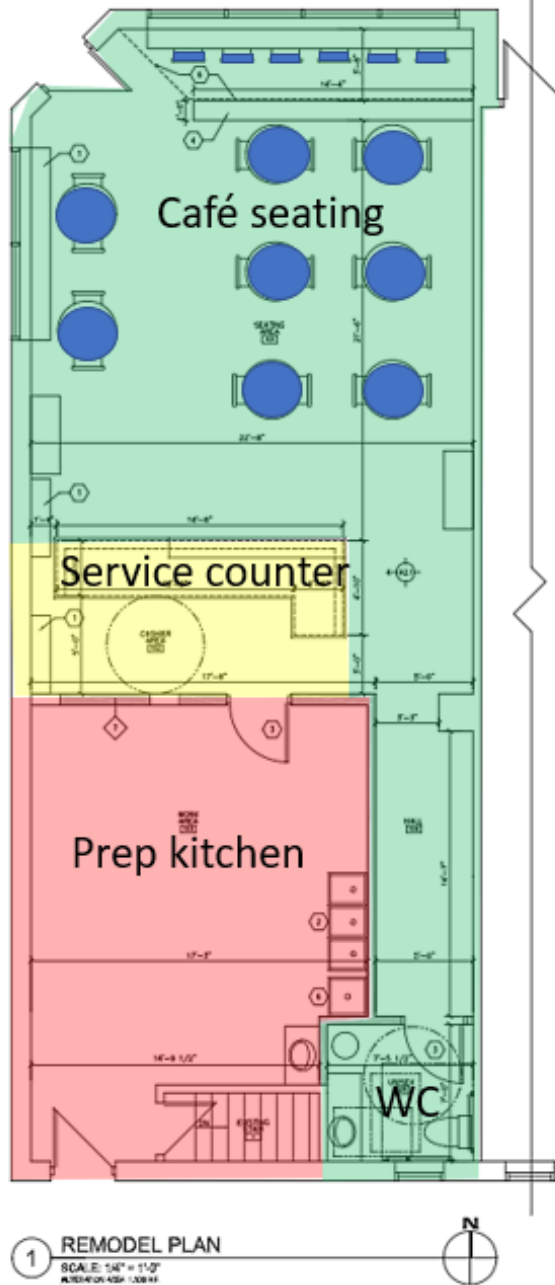

Floor Plan

The building interior will undergo alterations to suit the layout to the coffee shop's needs. The front portion of the shop area will be designated for customer seating; an existing window display platform (along the storefront windows) will be removed to allow additional counter seating along the front windows.

A retail service counter will be placed in the middle of the space. The back end will be used as a prep area for coffee and non-bake food items.

The alteration will provide public access via hallway to a remodeled, ADA compliant bathroom.

Site and Landscaping Plan

The property is nearly entirely built-out; no significant site and landscaping changes are proposed. Of note, staff will be reviewing the feasibility of relocating the dumpster(s) placement between the buildings. The dumpster is currently situated with City right-of-way along S. 77 St. There is a slight grade difference behind the building and the rear yards area is slightly lower than the adjacent city sidewalk. It appears that a platform was built years ago on private property for purpose of supporting a refuse container.

A surety requirement is not recommended by staff.



Architecture and signage

There are no proposed exterior alterations. Signage improvements will require a sign permit and may be approved administratively if the proposed signage meets the sign ordinance. General sign ordinance guidelines: [Sign-Handout-1-2-tenants \(westalliswi.gov\)](http://westalliswi.gov).

Recommendation: Common Council approval of the Special Use Permit for a restaurant use to be located at 7629 W. Greenfield Ave. and approval of the Site, Landscaping and Architectural Plans for Ethiopian Coffee Shop, a proposed cafe to be located at 7629 W. Greenfield Ave., submitted by Amina Bell. (Tax Key 452-0026-000), subject to the following:.

1. A revised site plan being submitted to the Planning and Zoning office: (a) specify general overall scope of improvements to the rear yard of the property, specifically refuse location, removal of remnant chain-link fence and clean-up/removal of weeds, graffiti and dead tree; (b) maintain access way to rear ingress/egress tenant doors.
2. Common Council approval of the special use. A public hearing before the Common Council is expect to be scheduled for February 17 at 6pm.



STAFF REPORT
WEST ALLIS PLAN COMMISSION
Wednesday, January 26, 2022
6:00 PM
City Hall – Room 128

Watch: <https://www.youtube.com/user/westalliscitychannel>

3. **Site, Landscaping, and Architectural Plans for a proposed professional office use to be located at 11548 W. Theo Trecker Way, submitted by Mark A. Molinaro Jr. (Tax Key 414-9992-017)**

Overview and Zoning

The property is zoned M-1, light industrial and is proposed to be leased for a professional office tenant (about 20,000-sf). Offices are permitted uses, but the tenant proposes to make site improvements including a fenced parking area and is also proposing to install/replace rooftop HVAC units.



Site, landscaping and Architectural

New fencing - The site plan, sheet A1.1 (below), indicates the proposed location of the fence to secure the vehicle parking and employee access to the building. The applicant proposes an 8-ft tall fence with privacy slats. A automated gated vehicle ingress/egress will be incorporated on the NW side of the fenced perimeter. In driving through the area, which is zoned light industrial, it is important to note that a fence of this height and material will not be out of ordinary.

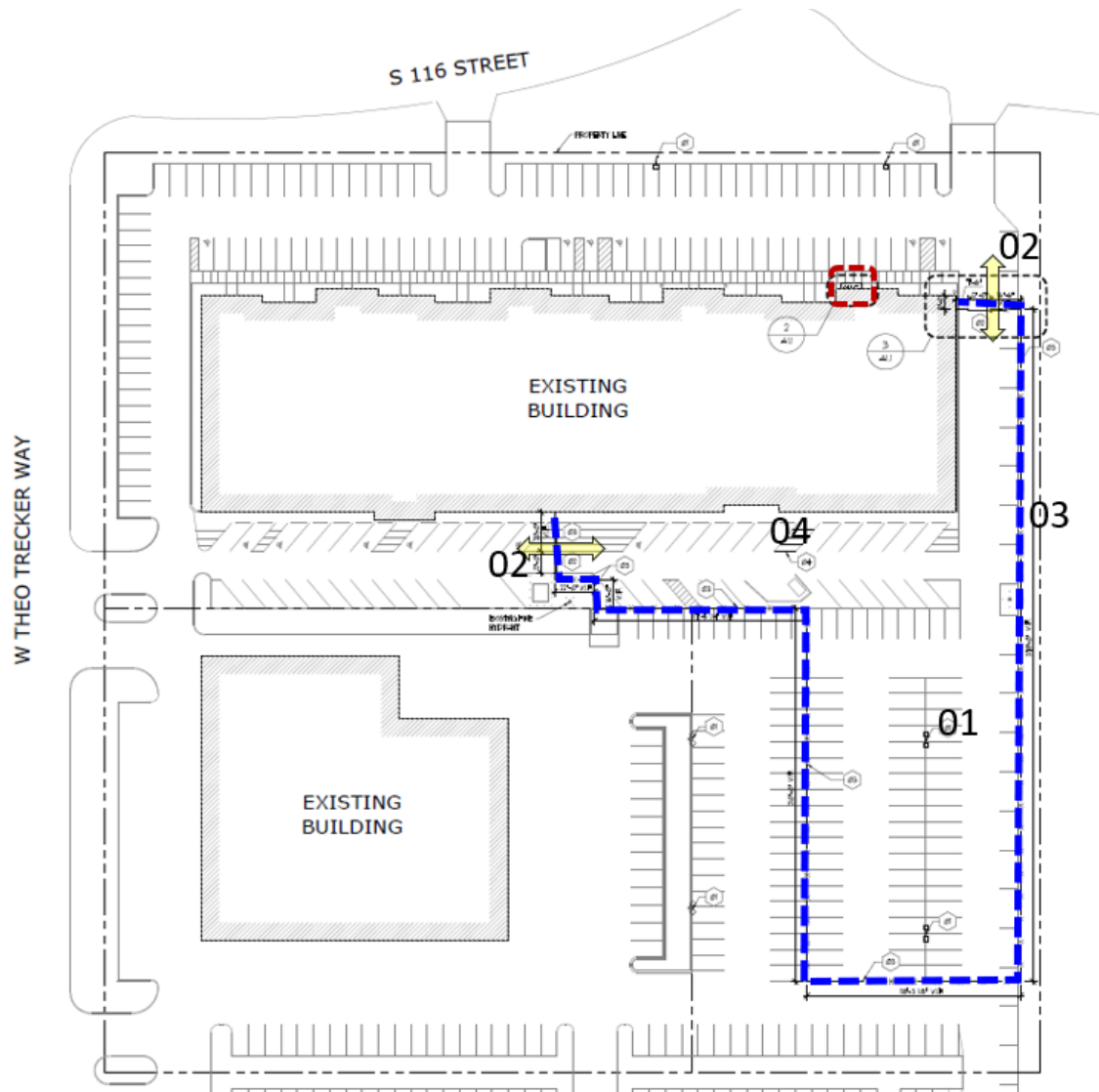

SHEET KEY NOTES

- 01 REPLACE HEAD ON EXISTING LIGHT POLE.
- 02 MOTORIZED SLIDE GATE. BASE OF DESIGN HOOVER FENCE. 8' HIGH CHAIN LINK FENCE STEEL CANTILEVER SLIDE GATE.
- 03 NEW 8' TALL CHAINLINK FENCE.
- 04 4' WIDE SOLID PAINTED STRIP - TYP.

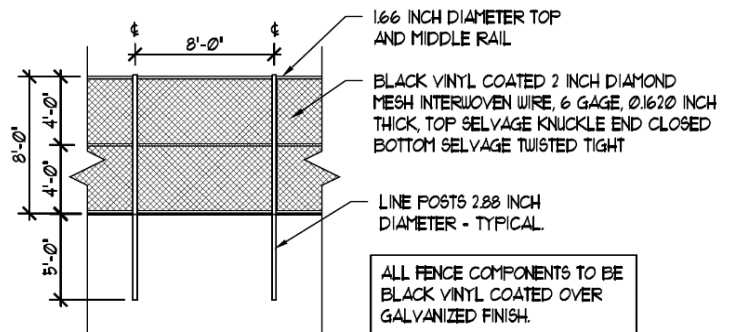

4 FENCE ELEVATION

Below - West side of building, new sidewalk approach

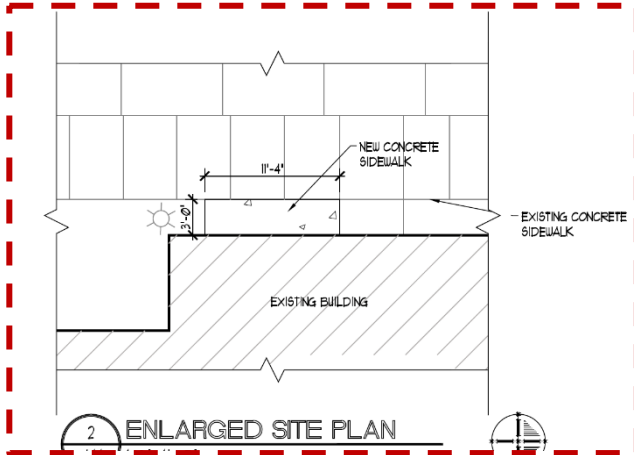

Roof top units (RTU) - The aerial image shows the existing building (birds eye view looking south toward W. Theo Trecker Way) and visual location of the existing roof top units.

The applicant will be removing 16 units on the north end of the building and replacing them with five new units (size specification on next page). In addition to having fewer units, only two of them will be on the Theo Trecker side of the roof and no closer to the west roof edge than the existing units. The new unit size is comparable to the size of the existing RTU.



Based on our review of the proposed changes, we do not believe roof screening will be required based on the unit positions, size and potential visibility of the units.

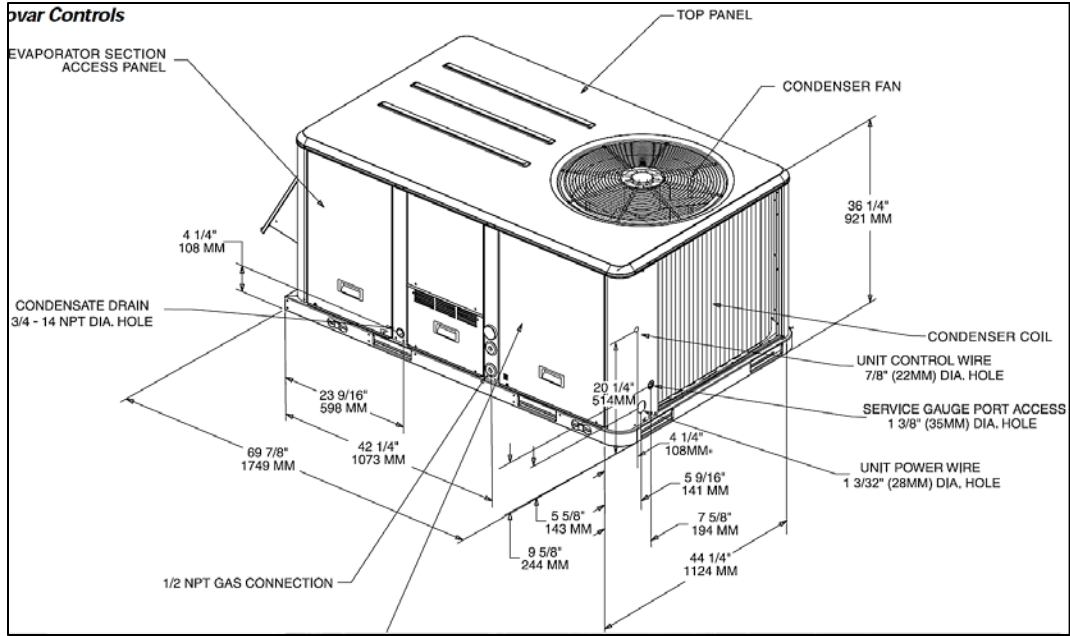

Recommendation: Approval of the Site, Landscaping, and Architectural Plans for a proposed professional office use to be located at 11548 W. Theo Trecker Way, submitted by Mark A. Molinaro Jr. (Tax Key 414-9992-017).



STAFF REPORT
WEST ALLIS PLAN COMMISSION
Wednesday, January 26, 2022
6:00 PM
City Hall – Room 128

Watch: <https://www.youtube.com/user/westalliscitychannel>

4. **Right of Way vacation, 29** S. Waukesha Rd. submitted by David Schneck and Joan Sternweis. (abutting Tax Keys 521-9948-000, 521-9947-003 & 521-9947-005)**

Overview and Zoning

The City has received a request for discontinuing a land-locked portion of City right-of-way just west of Waukesha Rd. (north of W. Oklahoma Ave. and South of W. Cleveland Ave.).

The property is zoned RA-1, residence district and is an undeveloped (wooded) portion of City right of Way. The applicants, Schneck & Sternweis, reside at 2949 S. Waukesha Rd. and their

properties abut the subject 60-ft x 115-ft property that is currently landlocked without street frontage to Waukesha Rd. (see area map below).



In staff's opinion, the portion of right-of-way serves no future public purpose and may be vacated in order for the city to convey title to the petitioner. If vacated, the land could then be consolidated with the two flanking parcels (to the east and west - also under same ownership) via Certified Survey Map.

Plan Commission's role is to determine if the subject land is consistent with the 2040 Comprehensive land use Plan. Of note, the land use plan classifies this area as low density residential lands use, and recommends the same over the next 20 years.

Our Engineering Department is not opposed to the discontinuance of this landlocked right-of-way.

Plan Commission's decision will be forwarded to the Common Council, and a public hearing will also be conducted in March as part of the public notice timeline.

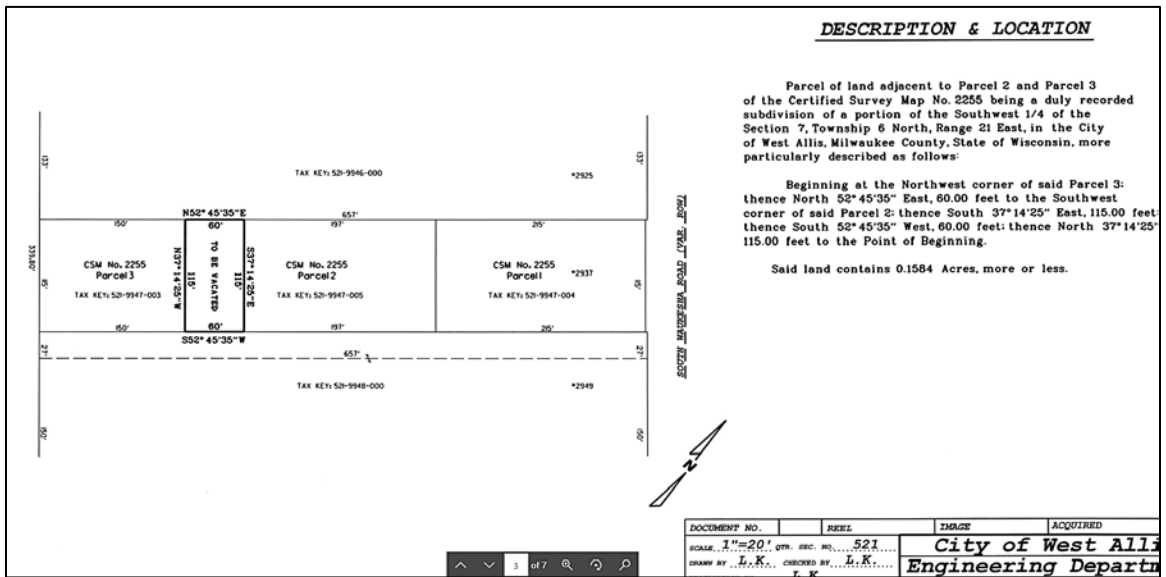

Schedule:

- Plan Commission consideration on 1/26
- Council introduction on 2/1 - may decide if they want to authorize staff to proceed with publishing notice or not. If not the item is placed on file.
- If we proceed with a public hearing other property owners within the area would be notified of a public hearing (likely in March).

Recommendation: Common Council approval of the Right of Way vacation, 29** S. Waukesha Rd. submitted by David Schneck and Joan Sternweis. (abutting Tax Keys 521-9948-000, 521-9947-003 & 521-9947-005).



**STAFF REPORT
WEST ALLIS PLAN COMMISSION
Wednesday, January 26, 2022
6:00 PM
City Hall – Room 128**

Watch: <https://www.youtube.com/user/westalliscitychannel>

5. Ordinance to repeal and recreate the City Zoning Code. (O-2022-0024, discussion only)

Overview

The City's Planning & Zoning team completed a preliminary draft of a comprehensive update to West Allis' zoning code. Over the years, the City's zoning code was built up piece by piece; as new ordinances were passed, new elements were added. The result is a code that is difficult for most people to understand. The code's complex structure is cumbersome to navigate and unnecessarily bulky. It also includes many redundancies and outdated elements that are no longer relevant. This makes the code less effective and more difficult to use. This comprehensive zoning code update will make the code easier to use, will allow for more taxable value in the city, and will better fit the West Allis of today and tomorrow.

Recommendation: Please review the draft documents to familiarize yourself with the proposed zoning code update.

Further discussion with elected officials will be held at the February 8th Safety & Development Committee meeting to address any feedback and edits.

A final version and presentation will be made to the Plan Commission at a future date. A public hearing before the Common Council will be required before passage.

Please send any comments or ask questions in advance by emailing staff at planning@westalliswi.gov.



User-Friendly Zoning Code Update Executive Summary

Council Members,

Please read the following documents so you may share your comments at the February Safety & Development Committee meeting. Feel free to send additional comments or ask questions in advance by emailing staff at planning@westalliswi.gov.

The City's Planning & Zoning team completed a preliminary draft of a comprehensive update to West Allis' zoning code. Over the years, the City's zoning code was built up piece by piece; as new ordinances were passed, new elements were added. The result is a code that is difficult for most people to understand. The code's complex structure is cumbersome to navigate and unnecessarily bulky. It also includes many redundancies and outdated elements that are no longer relevant. This makes the code less effective and more difficult to use.

The Planning & Zoning team is taking a big-picture perspective to envision how the City's zoning code can work best for the West Allis of today and tomorrow. To do so, the team identified key objectives of the zoning code update and several important strategies to meet each objective:

Objective 1: Easier to use

Reorganize, improve readability, eliminate redundancies

Objective 2: More taxable value

Allow more flexibility and density where appropriate, lower the code's burden to property owners

Objective 3: Fit the West Allis of today and tomorrow

Remove outdated elements, adopt zoning best practices, protect neighborhood character

This comprehensive update will impact many different aspects of the zoning code. The most significant proposed changes include:

Format

- Simplified organization
- Table-based code

Districts

- Consolidate redundant residential districts
- Update C-1 and C-2 district specific conditions

Uses

- Update terminology
- Remove obsolete uses
- Combine like uses into general categories and subcategories
- Update principal and accessory use criteria and restrictions
- New accessory uses (including Accessory Dwelling Units)

Structures

- Update residential structure regulations to promote conformance
- Update commercial structure regulations to promote flexibility and density

Parking

- Shift from minimum-based to maximum-based motor vehicle parking code
- Add low-burden bicycle parking requirement

User-Friendly Zoning Code Update

Detailed Overview

This document highlights the key changes proposed in the zoning code ordinance update.

Format

1. Simplified organization

The zoning code's current structure is confusing for users because it is not always clear where relevant information is located. Certain sections appear redundant, it is often difficult to make comparisons across districts, and its length is cumbersome. The proposed update will address this problem by shifting the format from district-by-district to step-by-step, so users will be able to find information in the order they need it.

Existing Zoning Code Structure *Chapter 12 Zoning and City Planning* *(Subchapter I Zoning Code)*

- Preliminary Provisions
- General Provisions
- Zoning District Regulations
 - RE Residential Estate District
 - RA-1 Residence District
 - RA-2 Residence District
 - RA-3 Residence District
 - RA-4 Residence District
 - RB-1 Residence District
 - RB-2 Residence District
 - RC-1 Residence District
 - RC-2 Residence District
 - C-1 Central Business District
 - C-2 Neighborhood Commercial District
 - C-3 Community Commercial District
 - C-4 Regional Commercial District
 - M-1/M-2 Industrial Districts
 - SF State Fair Park District
 - P-1 Park District
 - Mixed Residential and Commercial Use Structures
- Planned Development Regulations

Proposed Zoning Code Structure *Chapter 12 Zoning and City Planning* *(Subchapter I Zoning Code)*

- Administration
- Districts
- Uses
- Structures
- Parking
- Planned Development

The zoning code will be prefaced with the Administration section. This section will share relevant background information and the procedures related to the zoning code. Next, the Districts section will establish zoning districts and allows users to identify those relevant to their needs. Third, the Uses section will specify which uses are allowed in each district.

After determining the appropriate zoning district and which uses are allowed, users will proceed to determine how they can build on their property. The Structures section will establish the regulations for structures in each district while Parking will outline the requirements for motor vehicle and bicycle parking for each use.

Because it is rarely used, the Planned Development section will be placed last. This describes the powers of a planned development district and the process to create it.

2. Tables

The existing zoning code spells out regulations word by word in a list format. This makes it difficult to find relevant information, lengthy, and more difficult to make comparisons. In the proposed update, as much information as possible will be displayed in a table format. This will make the code cleaner, easier to use, shorter, and simpler to update.

Bulk Control	Bay Window	Chimney	Ornamental Features	Roof Overhang
Distance to Lot Line	Min 18"	Min 18"		
Projection	Max 3'	Max 3'	Max 18"	Max 3'
Proportion of Yard Area	Max 5%	Max 5%		

Example table from zoning code (12.33 Residential Building Feature Bulk Controls)

12.0 Administration

The Administration section largely consists of the former Preliminary and General Provisions sections. Further edits will be made by the City Attorney's Office. Several key changes include:

1. Relocation of non-administrative elements

Several subsections of the former Preliminary Provisions section will be moved. Former 12.04 Zoning Districts and 12.05 Zoning Map will form the new Districts section. Additionally, former 12.06 Definitions will no longer be located within the zoning code; definitions will have their own place in the City's code as part of the broader code update.

Several subsections from the former General Provisions will also be moved. Most of the subsections after 12.16 relate to accessory uses, this information will be included in the new Uses section. Meanwhile, former 12.19 and 12.20 will form the basis of the new Parking section.

2. Updated procedures

For the most part, the procedures relating to Site, Landscaping, and Architectural Review, Conditional Use Review, Board of Appeals, and Amendment Proposals will be updated to use clearer language and present information in a clearer manner. However, there will be some small substantive changes. Of note:

- 12.04(3)(b)(ii): Language will be added to align with recommendations of the Milwaukee Metropolitan Sewerage District to promote sustainable land and stormwater management.
- 12.04(3)(b): Language will be removed which detailed that designs shall not be overly similar or different from existing buildings and structures [former 12.13(9)(d)]. Effect is already covered by other criteria and could be interpreted as extending poor design quality.
- 12.04(3)(b): Language will be removed which detailed that designs shall use materials compatible with materials used in that area [former 12.13(9)(e)]. Effect is already covered by other criteria and could be interpreted as extending poor design quality.

12.1 Districts

1. District consolidation: RE → RA-1

This change will consolidate redundant large-lot, primarily single-family residential districts. Only 31 properties in the entire city are currently zoned RE. All 31 properties conform with RA-1 zoning regulations. Merging the RE properties into the RA-1 district promotes a cleaner, more efficient code.

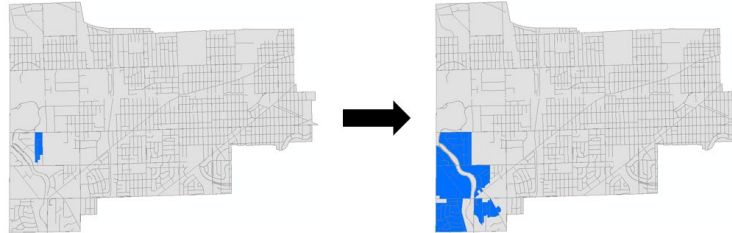

EXISTING RE AND PROPOSED RA-1

2. District consolidation: RA-4 & RB-1 → RA-3

This change will consolidate redundant small-lot, primarily single-family residential districts. Only 322 properties in the city are currently zoned RA-4 and 192 are zoned RB-1. Bulk regulations between the districts are limited, with minimal differences in lot area, lot width, and setbacks. Merging the RA-4 and RB-1 properties into the RA-3 district promotes a cleaner, more efficient code.

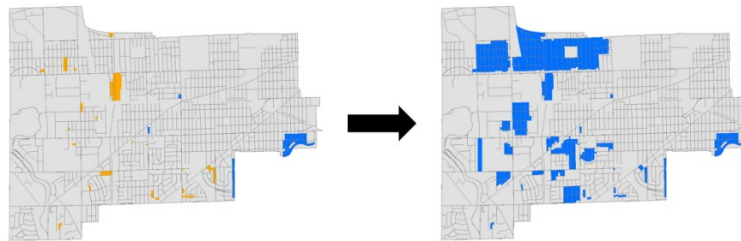

EXISTING RA-4 (BLUE) AND RB-1 (ORANGE) AND PROPOSED RA-3

3. District consolidation: RC-1 & RC-2 → RC

This change will consolidate redundant multi-family residential districts. Only 24 properties in the entire city are currently zoned RC-2. RC-1 and RC-2 have very limited bulk control differences that do not result in significant form differences. Merging the RC-1 and RC-2 properties into a single RC district promotes a cleaner, more efficient code.

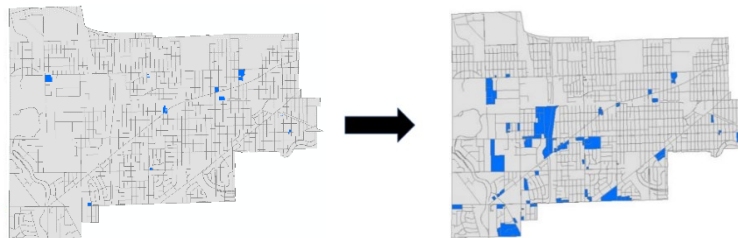

EXISTING RC-2 AND PROPOSED RC

4. District naming (12.10)

The existing code uses 2-part names for each zoning district. The first part is the commonly used abbreviation (ex: C-1) and the other is the written name which describes the intention of the district (ex: Central Business District). Each district also has a supplementary description to explain its intent. In the proposed update, each district will only have the abbreviated name and a brief description of its intent. This simpler format will be cleaner and more efficient and will provide less potential for legal challenges to zoning districts.

5. Add zoning map link (12.11)

While not included in this draft, an active link to the web-based zoning map will be added in MuniCode.

6. C-1 & C-2 district specific conditions (12.14)

The existing code includes a set of conditions that apply to all buildings in certain commercial districts. The update will reduce the number of conditions and adapt the existing ones to be simpler and better fit for the respective districts. The former required conditions will still be used internally by staff when making recommendations but removing them from the code itself provides more flexibility. These changes include:

- Remove C-1 requirement for open-backed display racks within 4 feet of windows
- Remove C-1 requirement for no parallel interior walls within 6 feet of windows
- Remove C-1 requirement for no permanent window coverings
- Remove C-2 requirement that no store may be in a building over 5,000 square feet (not enforced)
- Add C-2 requirement that interior wholesale, warehousing, and storage may not exceed 25% of the floor area

12.2 Uses

1. Update terminology

To make the permissions for each use clearer to users and better align with legal and zoning best practices, the update will add a new, more descriptive type of use “Limited Use,” remove “Transitional Use,” and change “Special Use” to “Conditional Use.”

Existing	Proposed
Permitted Use	Permitted Use
Transitional Use	
	Limited Use
Special Use	Conditional Use

Uses will also be renamed to represent the code’s intent more accurately.

2. Remove obsolete principal uses

Over the years, new uses were added to the City’s zoning code, but outdated uses were not removed. Today, many uses remain in the code which are no longer relevant. The proposed update will remove obsolete uses from the zoning code. Some examples of removed obsolete uses include mail order catalog stores, millinery shops, and travel bureau and transportation ticket offices.

3. Combine like principal uses into general categories and subcategories (12.21)

Uses will be grouped by general categories and further broken into subcategories and specific use types. For example, the “Retail” category includes a subcategory of uses for “Neighborhood Retail.” This subcategory includes a variety of more specific retail uses which share the same regulations and can be considered collectively. Other, specific uses such as “Nominal Price Retail Store” will continue to be regulated independently. This retains the City’s ability to control undesirable or sensitive uses.

This updated format for zoning uses is more efficient and will be better able to adapt to changes in development over time.

4. Update certain principal use permissions (12.21)

This proposal will also update the districts in which some uses are allowed or not allowed. This may occur in 2 ways: either a specific use was grouped into a broader subcategory or staff elected to change the permissions for a specific use. Below are the most significant changes, highlighted in blue with details listed below.

PRINCIPAL USE	RA-1	RA-2	RA-3	RB	RC	C-1	C-2	C-3	C-4	M-1	M-2	P	SF
Multi-Unit Dwelling (5 or more units)				C	P	C	C	C	C				
Community Living Arrangement (8 or fewer persons)	P	P	P	P	P		P	P	P				
Community Living Arrangement (9 or more persons)				C	C		C	C	C				
Tobacco Retailer								L	L	L	L		
Kennel									C	C	L		
Funeral Home							C	C	C	C	C		
Live Event/Theater (less than 5,000 sq. ft.)					C	P	P	P	P	P	P		
Live Event/Theater (5,000 or more sq. ft.)						C	C	C	C	P	P		
School/Daycare	C	C	C	C	C		C	C	C	C	C	C	C
General Park	C	C	C	C	C	C	C	C	C	C	C	P	
Indoor Gun Range									P	P	P		
Recreation Facility (indoor)						C	C	C	C	P	P	P	
Substation Distribution and Equipment										C	P	C	
Wireless Communication Structure										C	C		
Mixed Use (commercial and residential)					C	C	C	C	C	C			

- Multi-Unit Dwellings (5+ Units): *Previously not allowed in RB, will be conditional use*
- Community Living Arrangements: *Aligned with state statutes and intent of code*
- Tobacco Retailer: *Removed from C-1*
- Kennel: *Removed from C-4*
- Funeral Home: *Changed from permitted use to conditional use in C-4, M-1, and M-2*
- Live Event/Theater: *Extended to C-2, C-3, C-4 as a permitted or conditional use*
- School/Daycare: *Removed daycares from C-1*
- General Park: *Extended conditional use to all districts (except SF)*
- Indoor Gun Range: *Pending legal review, removed from C-2 and C-3*
- Recreation Facility (indoor): *Previously not allowed in C-2, C-3, C-4, will be permitted*
- Substation Distribution and Equipment: *Extended as conditional use to P district*
- Wireless Communication Structures: *Removed from C-3 and C-4*
- Mixed Use (commercial and residential): *Removed from M-2*

5. New principal use: Commercial Light Industrial Flex

One significant new use subcategory will be added as part of the update. Commercial Light Industrial Flex is intended to allow mixed commercial and light industrial uses beyond industrial districts. This would include uses like Able Distributing (1650 S 108 St) which mixes



a commercial showroom with industrial distribution and contractor supplies on the same site. The character of these uses fit with the character of the city's broader commercial districts and will be considered a conditional use in the C-3 and C-4 districts. Commercial Light Industrial Flex will also be considered a permitted use in the M-1 and M-2 districts.

6. Limited Use criteria (12.22)

The new subsection 12.22 will list criteria that must be met for Limited Uses to be permitted. Most of these limitations were already in place, such as the proximity buffer between Nominal Price Retail Stores. Most of the changes to limitations are minor language adjustments.

7. Conditional Use restrictions (12.23)

The new subsection 12.23 will list the restrictions that if met, will prohibit certain Conditional Uses. Most of these conditions were already in place.

Most of the changes to restrictions will be minor language adjustments. The only new restrictions include the following, and are open to council's input:

Use	Restriction
Fuel Sales	No Fuel Sales shall be located on a lot which directly shares a lot line with a lot zoned residential.
Motor Vehicle Service	No Motor Vehicle Service shall be located on a lot which directly shares a lot line with a lot zoned residential

8. Update certain accessory use permissions (12.24)

This proposal will also update the districts in which some accessory uses are allowed or not allowed. Changes are highlighted in blue with details listed below.

ACCESSORY USE	RA-1	RA-2	RA-3	RB	RC	C-1	C-2	C-3	C-4	M-1	M-2	P	SF
Instruction/Training Facility (15 or fewer persons)						P	P	P	P	P	P		
Outdoor Dining						L	L	L	L	L	L		
Outdoor Sales/Display						C	C	C	C	C	C		
Parking Lot/Structure					L	L	L	L	L	L	L	L	L
Production/Repair (less than 5,000 sq. ft.)						P	P	P	P	P	P		
Wireless Communication Collocation to Existing Structure	L	L	L	L	C	C	C	C	P	P	P	C	P

- Instruction/Training Facility: Previously only conditional use, if 15 or fewer will be permitted in the same districts
- Outdoor Dining: Changed from conditional to limited use
- Outdoor Sales/Display: Extended as conditional use to C-1
- Parking Lot/Structure: Reconfigured into 1 category, transitional use eliminated from residential districts, changed into a limited use
- Production/Repair: Extended as permitted use in C-1
- Wireless Communication Collocation to Existing Structures: Extended to additional districts with appropriate limitations or conditions

9. New accessory use: Accessory Dwelling Units

A key feature of the proposed update is the inclusion of Accessory Dwelling Units (ADUs) as an accessory use. ADUs are secondary, smaller residential dwelling units located on the same lot as a stand-alone home. This style of housing is growing increasingly popular across the country; it has the potential to increase housing affordability, taxable value, create a wider range of housing options,



and enable seniors to stay near their family as they age. The proposed regulations surrounding ADUs are based on those implemented by Wauwatosa but adapted to West Allis's specific context.

10. New accessory uses: Solar Energy and Wind Energy Systems

Solar Energy Systems and Wind Energy Systems will also be included as accessory uses. The regulations for these uses were listed separately in the code. Their inclusion as accessory uses makes the regulations clearer which promotes renewable energy production at the local level.

11. New accessory use criteria (12.25)

The new subsection 12.25 will list the criteria that must be met for accessory uses to be allowed. Most of these conditions were already in place. New or changed limitations and conditions include:

- Home Occupation: list of permitted occupations consolidated; home baking included to align with state laws.

12.3 Structures

1. Simplify lot size requirements

Currently, residential lot sizes are regulated by lot width and lot area. In the proposed update, lot area requirements will be eliminated. These requirements have limited applicability (they are only used for RA districts) and are redundant because the size of lots is also regulated by the lot width requirement. This change will promote a cleaner and more efficient code.

2. Update residential district regulations (12.30)

Several regulations will be changed in residential zoning districts to reduce the number of non-conforming properties and allow for desirable buildings that fit the context of their neighborhood.

- Height: Increase maximum by 5' in RB (formerly RB-2)
 - This will allow for greater flexibility and appropriate 3-4 Unit Dwelling heights without changing the character of existing neighborhoods.
- Lot Coverage: Increase by 20% in RB (formerly RB-2)
 - This will allow property owners more flexibility to maximize the space on the smaller lots of the RB district, increasing taxable value and the ability to build ADUs and other accessory structures.
- Lot Width: New minimums and maximums for RA-2, RA-3, and RB
 - This will protect neighborhood character by preventing overly small or overly large lots
 - RA-2: Approximately 37% of RA-2 lots have smaller widths than permitted. After change, only ~4% will have smaller or larger lots than permitted.
 - RA-3: Approximately 46% of RA-3 lots have smaller widths than permitted. After change, only ~5% will have smaller or larger lots than permitted.

- RB: Adding maximum to existing minimum will only increase nonconformance by ~0.7%.
- Front Setback: New minimums and maximums for RA-3 and RB
 - This “building envelope” style regulation specifies a range at which the front of the building must be located. This protects neighborhood character by preventing oddly placed buildings. Minimums are adjusted to increase conformance.
 - RA-3: 50 lots sampled. Change would have no impact on conformance rates.
 - RB: 50 lots sampled. Approximately 58% were closer than the existing minimum setback. After change, only 12% of sampled lots would remain nonconforming.
- Rear Setback: New rear setbacks for all RA and RB districts.
 - This will allow more flexibility for property owners
 - RA-1 & RA-2: Apply former corner lot rear setback to all
 - RA-3 & RB: Adopt former absolute minimum rear setback from RA-4 & RB
- Side Setbacks: New side setbacks for RA-3
 - Adopt the side setbacks of former RA-4 to promote conformance with district changes

3. Update commercial district regulations (12.30)

Several regulations will be changed in commercial zoning districts to allow for more desirable building forms and more density to grow the city’s taxable value.

- Floor Area Ratio (FAR): Increase FAR for RC and C-2
 - Allow for more desirable, denser development with greater taxable value
- Front Setback: Establish maximum front setback for C-1
 - Prevents buildings that do not fit the neighborhood’s character and maintains consistent main street streetscape design
- Side Setback: Establish side setbacks for C-4
 - Adopt uniform regulations with C-2 and C-3

4. Update structures in yards regulations (12.34)

Similar structures will be combined into categories (ex: Play Equipment). Language will also be added to better reflect when a structure is limited by certain regulations. The most significant individual change is the addition of 2 new structures:

- New structures: Cistern/Rain Barrels and Planter Boxes.
 - Added to align with recommendations of the Milwaukee Metropolitan Sewerage District to promote sustainable land and stormwater management.

12.4 Parking

1. Switch to maximum-based motor vehicle parking regulations (12.41)

Currently, the City’s parking regulations require property owners provide a minimum number of parking spaces. The minimum figures are based off the expected peak parking occupancy. Therefore, the regulations force property owners to provide more parking than will ever be needed. This regulation fills our city’s limited land area with unproductive, undesirable, low value, wasted space. It also discourages development by increasing the cost to developers, costs which are passed on to small business tenants and residents.



In the proposed zoning code, parking regulations will cap the maximum number of parking spaces. These maximum figures are also based off the potential peak parking occupancy but prevents wasting space rather than requiring it. Implementing parking maximums are a key strategy to growing the city’s taxable value by allowing for denser development. It will also allow for new redevelopment opportunities, particularly along the often overparked Highway 100 corridor. By giving the free market more flexibility to determine how much parking is appropriate, West Allis will encourage development and reduce the cost passed on to business tenants and residents.

Staff tested these regulations on existing uses with encouraging results. Most businesses and developments would not be impacted by changes in the parking code. The maximums will be typically set at or above the amount of parking already provided. Where the code will impact parking requirements, it will do so in a positive manner. Big box stores’ large, empty parking fields will be limited instead of required. Meanwhile, the parking requested by desirable developments will be allowed, without the administrative burden of waiving requirements through a variance.

Proposed code will limit over-parked development			
	Spaces Provided	Existing Code	Proposed Code
Home Depot	540	Min 465	Max 474
Former Sam’s Club	551	Min 427	Max 362
Dollar General	53	Min 46	Max 41

Proposed code will allow desirable development without variance			
	Spaces Provided	Existing Code	Proposed Code
SoNa	154	Min 176	Max 220
The West	293	Min 318	Max 354
Camino	0	Min 25	Max 80

2. Adjust certain motor vehicle parking regulations (12.42)

Several minor changes will be made to parking construction and shared use standards.

- Surfaces may be permeable asphalt or concrete
 - Adopted to align with recommendations of the Milwaukee Metropolitan Sewerage District to promote sustainable land and stormwater management.
- Adjust shared parking regulations to align with maximum-based code

3. Add bicycle parking requirements and regulations (12.43, 12.44)

Some light bicycle parking requirements will also be added within this update. These minimum bicycle parking requirements are intended to ensure that secure bicycle parking with consistent design standards is available and accessible for certain uses. This improvement will align the code with the City’s Complete Streets Policy, promote

accessibility for bicycling in the city, and prevent hazardous or unsightly temporary storage of bicycles in walkways.

These requirements are intended to be minimally burdensome. Small businesses below 3,000 square feet will not be required to provide bike parking. Only businesses of 9,000 square feet or more will be required to provide more than 1 bike rack. The City already regularly requires bicycle parking during the Site, Landscaping, and Architectural review process. These regulations will provide clear direction and consistent standards to employ throughout the city.

12.5 Planned Development

1. District Consolidation: PDD-1, PDD-2, & SPBD → PUD

The City currently has 3 overlay districts used for planned development. These districts are redundant and unnecessary, as each time an overlay district is used, new requirements will be made. In the proposed update, the City will use a single overlay district for planned development. This new district will be named “PUD” to better align with modern zoning terminology by representing “Planned Unit Development.”

2. Updated procedures

The procedures relating to Planned Development Districts will be updated to use clearer language and present information in a clearer manner.

Draft Zoning Code Ordinance



Chapter 12 Zoning and City Planning
Subchapter I Zoning Code

Prepared by the Planning & Zoning Office

Contents

12.0 Administration

- 12.00 Introductory Provisions
- 12.01 General Provisions
- 12.02 Violations and Penalties
- 12.03 Nonconforming Buildings, Structures, Lots and Uses
- 12.04 Site, Landscaping, and Architectural Review
- 12.05 Conditional Use Review
- 12.06 Board of Appeals
- 12.07 Amendment Proposals

12.1 Districts

- 12.10 Zoning Districts
- 12.11 Zoning Map
- 12.12 Split Zoning
- 12.13 C-1 and C-2 District Specific Conditions

12.2 Uses

- 12.20 Zoning Use Determination
- 12.21 Principal Use Table
- 12.22 Limited Use Criteria
- 12.23 Conditional Use Restrictions
- 12.24 Accessory Use Table
- 12.25 Accessory Use Criteria

12.3 Structures

- 12.30 Structure Regulations
- 12.31 Residential Accessory Building Regulations
- 12.32 Residential Building Feature Regulations
- 12.33 Structures in Yards

12.4 Parking

- 12.40 Introductory Provisions
- 12.41 Motor Vehicle Parking Table
- 12.42 Motor Vehicle Parking Regulations
- 12.43 Bicycle Parking Table
- 12.44 Bicycle Parking Regulations

12.5 Planned Development

- 12.50 Overlay Districts
- 12.51 Planned Development Procedures
- 12.52 Basis for Approval

12.0 Administration

12.00 Introductory Provisions

1. Authority: This Subchapter is created under the authority granted by sec. 62.23(7) of the Wisconsin Statutes.
2. Intent: The general intent of this Subchapter is to regulate and restrict the height, number of stories and size of buildings and other structures, the percentage of lot that may be occupied, the size of yards, courts and other open spaces, the density of the population and the location and use of buildings, structures and land for trade, industry, residence or other purposes; to lessen congestion in the streets; to secure safety from fire, panic and other dangers; to provide adequate light and air; to encourage the protection and enhancement of local air quality, water and other environmental resources; to further the orderly layout and use of land; to prevent the overcrowding of land; to avoid undue concentration of population; to facilitate the adequate provision of transportation, water, sewage, schools, parks and other public requirements; stabilize and protect property values; encourage the most appropriate use of land throughout the community; conserve natural resources; implement the community's comprehensive plan or plan components; and, otherwise promote the health, safety, morals, prosperity, aesthetics and general welfare of the Community.
3. Effective Date: This Subchapter was created by City Ordinance No. **TBD**, which took effect on **TBD**. Amendments shall become effective upon passage and publication, as provided in sec. 62.11(4) of the Wisconsin Statutes.

12.01 General Provisions

In both interpretation and application, the provisions of this Subchapter shall be held to be the minimum requirements adopted for promoting the general health, safety, convenience, and welfare of the residents of the City of West Allis.

1. Application
 - a. The provisions of this Subchapter shall govern whenever the regulations imposed by this Subchapter require a greater or lesser width or size of yards, courts or other open spaces, or require a lower height of building or less number of stories, or require a greater percentage of lot to be left unoccupied, or impose other higher standards than are required in any state statute or other City ordinance or regulation.
 - b. The provisions of any State Statute or other City ordinance or regulation shall govern whenever their provisions require a greater or lesser width or size of yards, courts or other open spaces, or require a lower height of building or less number of stories, or require a greater percentage of lot to be left unoccupied, or impose other higher standards than are required by the regulations of the Subchapter.
 - c. This Subchapter is not intended to repeal any easement, covenant, or any other private agreement, provided that where the regulations of this Subchapter are more restrictive or impose higher standards or requirements than such easements, covenants or other private agreements, the requirements of this Subchapter shall govern.
2. Control Over Use: No building or premises shall be used, in whole or in part, except in accordance with the provisions of this Subchapter as specified for the Zoning District in which any such building or premises is located.
3. Control Over Bulk: All new buildings and structures shall conform to the bulk requirements established in this Subchapter for the Zoning District in which each building or structure is located. No existing building or structure shall be enlarged, reconstructed, structurally altered, converted or

relocated in such a manner as to conflict with, or if already in conflict with, to further conflict with, the bulk regulations of this Subchapter for the Zoning District in which such building or structure is located.

4. Existing Buildings and Uses: All buildings and structures erected, all uses established, and all structural alterations and relocations of existing buildings and structures occurring after the effective date of this Subchapter or any amendment thereto shall be subject to the regulations of this Subchapter, as amended for the Zoning Districts in which such building, structures or uses are located.
 - a. Exception: Where a building permit has been issued in accordance with all other applicable regulations prior to the effective date of this Subchapter or any amendment, the permitted building or structure may be completed in accordance with the permit, as issued, and may be occupied for the originally intended use, subject to the regulations governing that use.
5. Building on a Lot: Every building hereafter erected or structurally altered shall be located on a lot. There shall be no more than 1 main building on a lot except in the case of those lands developed under the provisions of the Planned Development Section of this Subchapter. In case of doubt, or in any question of interpretation of this Subchapter, the decision of the Building Inspector shall be final.
6. Unoccupied Lots: Where a lot is occupied for a permitted use without buildings or structures, side yard and front yard requirements normally associated with the Zoning District in which the lot is located shall be maintained, unless otherwise stipulated in this Subchapter, except that side yards shall not be required on lots used for garden purposes without buildings or structures or on lots used for public recreational purposes.
7. Yards Apply to Single Building: No required yard or other open space around an existing building shall be considered as providing a yard or open space for any other building or for any other lot on which a building may be erected.
8. Exemptions for Public Premises: The regulations established in this Subchapter shall not apply to City premises, provided that a proposed development plan is submitted to the City Plan Commission for review and report to the Common Council, as required by Sec. 62.23 of the Wisconsin Statutes.
9. Root River Flood Control District: Within the area shown and designated on the Official Zoning Map as the Root River Flood Control District, no building or structure shall be erected, no existing building or structure shall be structurally altered, no building or structure shall be moved into the said area and no use of land shall be made except, in addition to all other applicable regulations of this Subchapter, in compliance with the specific regulations of the Root River Flood Control District. The regulations of the Root River Flood Control District shall be construed as supplementary to the regulations imposed on the same lands by any underlying zoning regulations. When flood control and underlying zoning regulations conflict, the most restrictive regulations shall govern.
10. The Building Inspector and Director of Development or their designees shall administer and enforce the provisions of this Subchapter.

12.02 Violations and Penalties

1. It shall be unlawful to erect, construct or reconstruct any building or structure or to use any building, structure or premises in violation of any provision of this Subchapter.

2. Any person, firm or corporation violating any provision of this Subchapter shall, for each offense, forfeit not less than \$25, nor more than \$500, together with the costs of prosecution; and, in default of payment of such forfeiture and costs, by imprisonment in the Milwaukee County House of Correction until payment of the forfeiture and costs, but not in excess of the number of days set forth in Sec. 800.095 of the Wisconsin Statutes. Each and every day a violation of a provision of this Subchapter continues constitutes a separate offense.
3. In case any building or structure is or is proposed to be erected, constructed or reconstructed or any building, structure or premises is proposed to be used in violation of the provisions of this Subchapter, the Building Inspector or the City Attorney or any adjacent or neighboring property owner who would be specially damaged by such violation, may, in addition to other remedies provided by law, institute injunction, mandamus, abatement or any other appropriate action or proceeding to prevent, enjoin, abate or remove any such violation.

12.03 Nonconforming Buildings, Structures, Lots and Uses

1. Authority to Continue. All nonconforming buildings, structures and uses may be continued subject to the provisions of this Subchapter.
2. Nonconforming Buildings and Structures.
 - a. Alteration and Enlargement: No nonconforming building or structure in which there is a conforming use may be enlarged or structurally altered if the enlargement or alteration will extend the nonconformity.
 - b. Relocation: No nonconforming building or structure shall be moved, in whole or in part, to any other location on the same or any other lot unless, upon relocation, every part of such building or structure is made to conform to all applicable regulations of the Zoning District in which it is located.
 - c. Reconstruction: A nonconforming building or structure, which is damaged or destroyed by fire or other casualty, including natural disaster, shall not be restored if the cost of restoration exceeds 50% of its assessed value at the time of such loss, unless the building or structure is made to conform to all applicable regulations of the zoning district in which it is located.
3. Nonconforming Uses
 - a. Repair and Maintenance: Ordinary repair and maintenance are permitted for a building or structure occupied by a nonconforming use, including repairs which may be required by law to make the building or structure, or any part thereof, strengthened or restored to a safe condition. However, total structural repair shall not, during the life of any such building or structure, exceed 50% of its assessed value at the time the use became nonconforming, unless the use has changed to a use permitted in the zoning district in which it is located.
 - b. Alteration, Enlargement or Relocation. No building or structure occupied by a nonconforming use shall be enlarged, reconstructed, relocated or structurally altered unless the use of the building or structure is changed to a use permitted in the Zoning District in which it is located.
 - c. Restoration. A building or structure occupied by a nonconforming use, which is destroyed or damaged by fire or other casualty, including natural disaster, shall not be restored if the cost of restoration exceeds 50% of its assessed value at the time of such loss, unless the use of the building or structure is changed to a use permitted in the zoning district in which it is located.
 - d. Extension of Use. No nonconforming use of a building or structure shall be increased in intensity or extended to any part of the building or structure it occupies that was not intended or designed to be devoted to such use on the effective date of this Subchapter or any amendment which made such use nonconforming, nor shall any such use be extended to occupy any land outside the building or structure.
 - e. Change of Use. The nonconforming use of a building or structure may only be changed to a use permitted in the Zoning District in which the building or structure is located.

- f. Discontinuance of Use. No nonconforming use of a building or structure shall be resumed if abandoned or discontinued for a period of 12 months. Any discontinuance caused by governmental action and without any contributing fault by the nonconforming user shall not be considered in calculating the length of the discontinuance.

4. Nonconforming Lots

- a. Any platted lot of not less than 40 feet in width in an approved subdivision, which plat was of record prior to February 24, 1956, but which does not meet the lot width and area regulations of the Zoning District where the lot is located may be utilized for a single-family dwelling, provided that, the lot area is within 75% of that required in any such Zoning District.
- b. Where an unplatted lot does not meet the lot width and area regulations of the Zoning District where the lot is located, the lot may be utilized for a 1-Unit Dwelling, provided that such lot width and area are within 75% of that required in any such Zoning District.
- c. Where platted or unplatted lots have a greater width or area than is required by the regulations in the Zoning District where the lot is located, such lots shall not be divided or reduced in width or area less than that required by the regulations in any such Zoning District.
- d. Any 1-Unit Dwelling permitted to be constructed under this Subsection shall, at a minimum, meet the front yard and 75% of all other yard requirements in the Zoning District where the lot is located.

5. Nonconforming Conditional Uses

- a. Existing Conditional Uses. Conditional uses lawfully existing on the effective date of this Subchapter or any amendment thereto, which do not conform to applicable regulations governing use in the Zoning District in which that use is located, constitute a nonconforming use.
- b. Reclassified Uses. A permitted use of a building, structure or land lawfully existing on the effective date of this Subchapter which has been reclassified as a conditional use under this Subchapter shall be held to be a valid use subject to the provisions of this Section.

12.04 Site, Landscaping, and Architectural Review

The purpose of this Section is to establish site and architectural standards for development projects in the city in order to provide for adequate and convenient open space for recreation, light and air; to promote aesthetically compatible development; to promote stability and improvement in and avoid substantial depreciation in property values; to avoid population congestion; to maintain and promote pedestrian and vehicular circulation; to promote the long term health, safety and general welfare and happiness of the community; and, to otherwise promote the purposes and intent of this Subchapter.

No building permit for the construction of any building, structure or project to which this section applies shall be issued until a site and architectural plans therefore have been reviewed and approved pursuant to this section. Site improvements not requiring a building permit but subject to site plan approval shall not be commenced until approved pursuant to this section.

1. Review Required

- a. Site, Landscaping, and Architectural Review is required for any of the following: new construction, change of use, additions to existing buildings, exterior alterations or repairs to existing buildings for which a building permit is required, a conditional use permit is required, or site changes.
- b. Exception: Site, Landscaping, and Architectural plans of new construction or conversion with exterior modification for 1-Unit or 2-Unit Dwellings do not require Plan Commission review, but shall be reviewed by the Planning & Zoning office.
 - i. If unable to come to an agreement on the proposed design, the applicant may file a request for review with the Plan Commission.

- ii. 1-Unit and 2-Unit Dwellings are exempt from any surety bond requirements.

2. Authority

- a. Site and architectural plans will be subject to review and approval by the Plan Commission, as provided in this section.
- b. In approving any site and architectural plans, the Plan Commission shall have the authority to stipulate those conditions it deems necessary to protect the public interest and to secure compliance with this section.
- c. The Plan Commission shall have the authority to adopt reasonable rules and regulations relative to the exercise of its powers under this section. Such rules may include specific site and architectural design criteria that serve to implement the general standards set forth in 3(b). Rules will become effective only after they have been approved by the Common Council following due notice and public hearing. Publication of this notice will be as required for a Class II notice under Wisconsin Statutes.
- d. As a condition of approving a site plan, the Plan Commission may require that the applicant provide a security bond, letter of credit or cash deposit to ensure the completion of all required site improvements.
 - i. The form of the bond or other security, if any, shall be prescribed by the Plan Commission.
 - ii. The amount of any bond or other security may not exceed 125% of the estimated cost of the site improvements and may be reduced over the life of the construction of the project as elements are completed; however, even if the amount is reduced, the bond or other security will remain in force until all required site improvements have been completed and approved by the Building Inspector.
 - iii. The Plan Commission may require more than 1 estimate from licensed contractors to determine the value of the bond or security.
- e. The Plan Commission shall have the power to approve, approve with conditions, or reject a site or architectural plan based on the requirements specified in this section and those rules adopted and approved pursuant to 2(c).

3. Procedure

- a. Application: The applicant must submit an application with the Planning & Zoning Office. The application shall include the following:
 - i. Completed application and fee determined by the Planning & Zoning Office.
 - ii. Project description.
 - iii. Site, Landscaping, and Architectural plans.
- b. Plan Commission Review: Site and building designs shall:
 - i. Provide for the placement of all site elements necessary to create a safe, functional, convenient, healthful, durable and attractive environment.
 - ii. Preserve the positive features of the site to the extent possible and minimize their destruction or harmful alteration. In particular, site and landscape designs shall protect mature trees and soils, and use landscaping and natural features to manage and infiltrate stormwater runoff wherever practicable.
 - iii. Ensure that all developments function within the context of the site and the surrounding area. Site designs shall eliminate, or if not possible to eliminate, mitigate potential hazards created by the proposed development.
 - iv. Be designed in accordance with site and architectural design criteria adopted and approved in accordance with 3(c).
- c. Plan Commission Decision: The Plan Commission may approve, approve with conditions, or reject the application.
 - i. The Plan Commission decision shall be in writing and contain a statement of reasons for its action. Any conditions of approval shall be specifically stated in the decision. A copy of the Plan Commission decision will be sent to the applicant and owner, if different from the applicant.

- ii. The Plan Commission decision on an application shall be issued within 60 days of filing of the application with the Planning & Zoning Office unless the applicant has agreed in writing to an extension.
 - d. Appeals: Any person aggrieved by a decision of the Plan Commission under this section may appeal that decision to the Common Council.
4. Effect of Approval: Building permits and certificates of occupancy shall be consistent with plans approved by the Plan Commission. Construction, location and use of all buildings and structures shall also be consistent with the approved plans.
- i. Sites, buildings, and structures will be completed and maintained in accordance with the final plans approved pursuant to this section.
 - ii. Approved plans will run with the land and will remain in effect regardless of changes in ownership of the subject property.
5. Approval Expiration: Approval will expire 1 year from the date of approval unless construction is underway, or the applicant has been granted a valid building permit. If construction is underway or a building permit has been granted after 1 year from the date of approval, the approval will expire if construction is not completed within 2 years of the Plan Commission decision.
- a. Extension of Time: An extension of time of the time limitations may be granted by the Plan Commission with the following criteria:
 - i. The applicant requesting the extension shall complete a planning application available from the Department of Development and shall submit an extension fee. The fee may be waived at the discretion of the Planning & Zoning Manager.
 - ii. A written explanation for the extension of time shall accompany the planning application along with a timeline/schedule for obtaining necessary permits, zoning, state and municipal approvals and a target date for construction start.
 - iii. The request for extension shall be submitted within 60 days of the expiration of the Plan Commission approval, and the Plan Commission shall decide on the length of the requested extension of time.
6. Approval Revocation: The Plan Commission shall have the authority to revoke its approval of a site and/or architectural plan if the provisions of that plan are not fully implemented.
7. Conditional Occupancy: In the event the completion of all required site improvements are delayed due to work stoppages, extraordinary or seasonal weather conditions or damage caused by fire, or other casualty, a conditional occupancy for the project, or any part thereof, may be approved by the Building Inspector.
- a. This approval shall be subject to whatever terms and conditions are deemed necessary by the Building Inspector to protect the public interest and promote and secure compliance with the purposes and intent of this section. No conditional occupancy will be allowed unless the improvements to be occupied are approved for occupancy by the Building Inspector.
 - b. All required site improvements will be completed within a period set by the Building Inspector from the date of approval of the conditional occupancy.
 - c. The approval of a conditional occupancy will not be interpreted as a waiver of any of the applicant's obligations under this section, except to extend the time for completion of the site improvements as provided in b.
8. Re-Application: No application which has been wholly, or in part, rejected may be resubmitted until at least 1 year from the date of the final action of the Plan Commission, except in the case of newly discovered evidence or proof of changed conditions.
9. Amendments: No modification or alteration of any plan approved pursuant to this section will be permitted unless approved in writing by the Plan Commission.

- a. An application for any such alteration or modification shall be filed with the Plan Commission on a form approved by the Plan Commission.
- b. Alterations and modifications shall be subject to the same standards and criteria as original applications and shall be in conformance with all the provisions of this section.

12.05 Conditional Use Review

Within each Zoning District, there are various permitted uses. There are also various other uses which are required for the public convenience but are potentially incompatible with permitted uses and which can have a deleterious impact on the surrounding area. This impact cannot be predetermined or controlled by general regulations. In addition, these conditional uses cannot always be confined to specific Zoning Districts. Therefore, to ensure compatibility with the neighborhoods in which they may be located, it is necessary that these conditional uses not be permitted as a matter of right, but only after appropriate review and approval as provided by this Section.

Conditional uses may be granted by the Common Council, as provided under the provisions of the Section, in the respective Zoning Districts in which they are allowed.

1. Standards for Approval

- a. The establishment, maintenance or operation of the conditional use will not be detrimental or endanger the public health, safety, morals, comfort or general welfare and will not otherwise conflict with the purpose and intent of this Subchapter.
- b. The use, value and enjoyment of other property in the surrounding area for permitted uses will not be substantially impaired or diminished by the establishment, maintenance or operation of the special use.
- c. The establishment of the conditional use will not impede the normal and orderly development and improvement of surrounding property for permitted uses in the Zoning District.
- d. Adequate utilities, access roads, drainage and other necessary site improvements have been or are being provided.
- e. Adequate measures have been or will be taken to provide ingress and egress to minimize traffic congestion in the public streets.
- f. Adequate measures have been or will be taken to encourage walking, biking, and transit trips in a manner that considers the context of the surrounding community as well as the broader urban design needs of the city.
- g. The conditional use will comply with all additional regulations imposed on it by the particular provision of this Subchapter authorizing such use.

2. Authority

- a. In granting any conditional use, the Common Council shall have the authority to change the minimum or maximum requirements specified for such uses in the respective Zoning Districts and shall establish such regulations and impose such conditions and restrictions on the use as are reasonably necessary to secure compliance with the standards set forth in this section and subchapter.
- b. The regulations that are established and any conditions and restrictions that are imposed shall be expressly set forth in the resolution granting the conditional use and shall govern the development, use and occupancy of the property, subject to such other required permits and approvals, including, but not limited to site and architectural approvals under Section 12.04 of this Subchapter and a building permit under Chapter 13 of this Code.

3. Procedure

- a. Application: The applicant must submit an application with the Planning & Zoning Office. The application shall include the following:

- i. Completed application and fee determined by the Planning & Zoning Office.
 - ii. Project description.
 - iii. Site, Landscaping, and Architectural plans.
 - b. Addition to Common Council Agenda: Upon receipt of an application, the City Clerk will place the application on the agenda of the Common Council. The Common Council will refer the matter to the City Plan Commission and Safety and Development Committee for review and a recommendation.
 - c. Plan Commission Review: The City Plan Commission will review the Site, Landscaping, and Architectural plans associated with the Conditional Use application in the same manner as described in 12.04(3)(b).
 - d. Safety and Development Committee Review: The Safety and Development Committee of the Common Council will meet to review the recommendations of the Plan Commission.
 - i. Members of the public will be allowed to address the Committee with the approval of the Chair. The Safety and Development Committee will make its own decision on the application which may agree or disagree with that of the Plan Commission. The decision of the Committee will be forwarded to the Common Council along with the recommendation of the Plan Commission.
 - e. Common Council Public Hearing: A public hearing shall be held by the Common Council.
 - i. Notice of the time and place of the hearing shall be made in the official City newspaper as a Class II notice, as provided by law. The City Clerk will mail the notice of the hearing to the applicant, his agent or attorney, at least 10 days before the date of the public hearing. In addition, the City Clerk shall mail notice of the hearing to property owners within 200 feet of the effected property at least 10 days prior to any such hearing, but failure to give such notice shall not invalidate any amendments.
 - f. Common Council Decision: Following the public hearing and receipt of the recommendations of the Plan Commission and the Safety and Development Committee, the Common Council will render a final decision on the application. This decision will be to approve, disapprove or refer the application back to the Safety and Development Committee for further study.
 - i. The Common Council will render its written decision within 60 days of the close of the public hearing. The written decision will include all the reasons for granting or denying the permit, including specific reference to the standards found in Subsection (1) and a record of the vote of the Common Council. The City Clerk will mail the written decision to the applicant.
 - ii. A majority vote of the Common Council is necessary to permit or deny a special use.
4. Effect of Approval: Building permits and certificates of occupancy shall be consistent with plans approved by the Common Council. Construction, location and use of all buildings and structures shall also be consistent with the approved plans.
- a. Sites, buildings, and structures will be completed and maintained in accordance with the final plans approved pursuant to this section.
 - b. Approved plans will run with the land and will remain in effect regardless of changes in ownership of the subject property.
5. Approval Expiration: Approval will expire 1 year from the date of approval unless construction is underway, or the applicant has been granted a valid building permit. If construction is underway or a building permit has been granted after 1 year from the date of approval, the approval will expire if construction is not completed within 2 year of the Plan Commission decision.
- a. Extension of Time: An extension of time of the time limitations may be granted by the Plan Commission with the following criteria:
 - i. The applicant requesting the extension shall complete a planning application available from the Department of Development and shall submit an extension fee. The fee may be waived at the discretion of the Planning & Zoning Manager.
 - ii. A written explanation for the extension of time shall accompany the planning application along with a timeline/schedule for obtaining necessary permits, zoning, state and municipal approvals and a target date for construction start.

- iii. The request for extension shall be submitted within 60 days of the expiration of the Plan Commission approval, and the Plan Commission shall decide on the length of the requested extension of time.
- 6. Approval Revocation: The Plan Commission shall have the authority to revoke its approval of a site and/or architectural plan if the provisions of that plan are not fully implemented.
- 7. Conditional Occupancy: In the event the completion of all required site improvements are delayed due to work stoppages, extraordinary or seasonal weather conditions or damage caused by fire, or other casualty, a conditional occupancy for the project, or any part thereof, may be approved by the Building Inspector.
 - a. This approval shall be subject to whatever terms and conditions are deemed necessary by the Building Inspector to protect the public interest and promote and secure compliance with the purposes and intent of this section. No conditional occupancy will be allowed unless the improvements to be occupied are approved for occupancy by the Building Inspector.
 - b. All required site improvements will be completed within a period set by the Building Inspector from the date of approval of the conditional occupancy.
 - c. The approval of a conditional occupancy will not be interpreted as a waiver of any of the applicant's obligations under this section, except to extend the time for completion of the site improvements as provided in b.
- 8. Re-Application: No application which has been wholly, or in part, rejected may be resubmitted until at least 1 year from the date of the final action of the Plan Commission, except in the case of newly discovered evidence or proof of changed conditions.
- 9. Amendments: No modification or alteration of any plan approved pursuant to this section will be permitted unless approved by the Common Council.
 - a. Any application for an alteration, extension or other modification will be filed and processed as an original application under this section.
 - b. Alterations and modifications shall be subject to the same standards and criteria as original applications and shall be in conformance with all the provisions of this section.
 - c. Maintenance, repair or renovation of existing buildings, structures or improvements and alterations, extensions or other modifications of such buildings and structures which do not increase, intensify, expand or substantially change the character of the conditional use do not require approval by the Common Council.

12.06 Board of Appeals

Under the provisions of Sec. 62.23(7)(e) of the Wisconsin Statutes, the City of West Allis creates a Board of Appeals, the purpose of which is to ensure that adequate, but controlled, flexibility is provided in the application of this Subchapter. The Board will be governed by the provisions of the State Zoning Enabling Law and the rules of procedure found in this Subchapter. In the case of any conflict between these two, state law will prevail over local ordinances.

- 1. The Board of Appeals shall be constituted as prescribed by Section 2.39 of this Code and Sec. 62.23(7)(e)2. of the Wisconsin Statutes.
- 2. Jurisdiction and Rules: The Board of Appeals shall have the following specified duties and powers:
 - a. The Board will hear and decide appeals where it is alleged that there is an error in any order, requirement, decision, determination or interpretation made by an official in the enforcement of this Subchapter.

- b. The Board may authorize, upon appeal, such variances from the terms of this Subchapter as will not be contrary to the public interest where, owing to special circumstances, a literal enforcement of the provisions of this Subchapter will result in practical difficulty or unnecessary hardship and the variance will ensure that the spirit of the Subchapter is observed, the public safety and welfare secured and substantial justice done.
- c. The jurisdiction of the Board to grant variances shall not extend to any variance involving the establishment or continuation of a use or uses which would be prohibited in the Zoning District for which the variance is sought, nor shall it have jurisdiction to permit variances from land area per dwelling unit requirements in any such District or permit variances which would otherwise result in substantial detriment to the public good and substantially impair the intent and purpose of this Subchapter.
- d. The Board shall grant no variance due to a self-imposed economic hardship.
- e. In granting a variance, the Board may specify, in writing to the applicant, such conditions of the variance that will, in its judgment, substantially secure the objectives of the regulations or provisions to which the variance applies. The breach of any of these conditions will automatically invalidate the variance.
- f. No application or appeal which has been denied, wholly or in part, by the Board may be resubmitted for a period of 1 year from the date of the last denial, except on the grounds of new information or changed conditions which are found valid by the Board upon inspection.
- g. Any variance granted will become null and void, unless the stated provisions of the variance have been utilized by the applicant within 6 months of the granting of the variance unless otherwise noted by the Board.

3. Procedures: The Board shall have the authority to develop rules and procedures to govern its work under the provisions of this Subchapter.

12.07 Amendment Proposals

Amendments to this Subchapter, or the Official West Allis Zoning Map, are within the legislative authority of the Common Council. The Common Council may, in the exercise of its discretion, entertain proposals for amendments upon petition of one or more owners of property to be affected by the proposed amendment. In such cases, the process outlined in this Section should be adhered to. However, nothing in this Section should be construed to in any manner define or limit the authority of the Common Council nor create any procedural right or entitlement.

- 2. Criteria: In considering petitions for amendment, the Plan Commission and the Common Council shall use the following as guidelines:
 - a. The property in question cannot be reasonably used as currently zoned.
 - b. The proposed change is supported by the adopted City Comprehensive Land Use Plan.
 - c. The change is consistent with the established land use pattern.
 - d. The existing infrastructure, including the street system, public and private utilities and City-provided services, can accommodate the proposed change.
 - e. The proposed change does not have a negative impact on the natural environment, including floodplains, natural drainage ways and natural areas within and adjacent to the City.
 - f. The request constitutes a continuation or an extension of an existing Zoning District.
 - g. A change in conditions in the area supports the proposed amendment or map change.
 - h. The proposed request is consistent with the needs of the community.

3. Procedures: The procedure for amending this Subchapter or the Zoning Map is as follows:

- a. Written Request: A written request from the applicant, addressed to the Mayor and Common Council and submitted to the City Clerk.
 - i. The request shall state the proposed amendment to this Subchapter or the Zoning Map. The letter of application shall also include the reason for the request and any appropriate documentation and shall be accompanied by the necessary application fee. The Common Council has set a fee schedule for this process. The office of the City Clerk has a list of appropriate fees.
 - b. Addition to Common Council Agenda: Upon receipt of an application, the City Clerk will place the application on the agenda of the Common Council. The Common Council will refer the matter to the City Plan Commission for review and a recommendation.
 - i. The City Plan Commission is advisory to the Common Council. All final decisions are made by the Common Council.
 - c. Plan Commission Review: The City Plan Commission will review the application in an open public session.
 - i. Members of the public will be allowed to address the Commission. Public comments will be considered by the Commission in their recommendation. Recommendation shall be made within 60 days from referral of the application. Recommendations of the Commission will be forwarded to the Safety and Development Committee of the Common Council for further consideration.
 - d. Safety and Development Committee Review: The Safety and Development Committee of the Common Council will meet to review the recommendations of the Plan Commission.
 - i. Members of the public will be allowed to address the Committee with the approval of the Chair. The Safety and Development Committee will make its own decision on the application which may agree or disagree with that of the Plan Commission. The decision of the Committee will be forwarded to the Common Council along with the recommendation of the Plan Commission.
 - e. Common Council Public Hearing: If a majority of the Safety and Development Committee approve the application, a public hearing shall be scheduled by the Common Council.
 - i. Notice of the time and place of the hearing shall be made in the official City newspaper as a Class II notice, as provided by law. In addition, the City Clerk shall mail notice of the hearing to property owners within 200 feet of the effected property at least 10 days prior to any such hearing, but failure to give such notice shall not invalidate any amendments.
 - f. Common Council Decision: Following the public hearing and receipt of the recommendations of the Plan Commission and the Safety and Development Committee, the Common Council will render a final decision on the application. This decision will be to approve, disapprove or refer the application back to the Safety and Development Committee for further study.
4. Re-Application: No application for an amendment to this Subchapter, which has been wholly, or in part, disapproved may be resubmitted for a period of 1 year from the date of final Common Council action on the original application, except in the case of new information or changed conditions which are found valid by the Common Council upon inspection.

12.1 Districts

12.10 Zoning Districts

To regulate and restrict the location of various types of activities and land use, the City of West Allis is divided into the following Zoning Districts:

Zoning Districts	
Residential Districts	
RA-1	Intended for neighborhoods with primarily 1-unit dwellings on large lots.
RA-2	Intended for neighborhoods with primarily 1-unit dwellings on moderate sized lots.
RA-3	Intended for neighborhoods with primarily 1-unit dwellings on small lots.
RB	Intended for traditional neighborhoods with a diverse array of housing types on small lots.
RC	Intended for dense, multi-unit housing development in areas throughout the city.
Commercial Districts	
C-1	Intended for the city's historic pedestrian-oriented downtown shopping district.
C-2	Intended for a mix of uses in close proximity to residential areas that are compatible with the neighborhood scale.
C-3	Intended for commercial development serving the broader community's daily needs.
C-4	Intended for large-scale, automobile-oriented commercial development serving the needs of the regional population.
Manufacturing Districts	
M-1	Intended for lower-intensity, non-nuisance industrial uses in closer proximity to residential and commercial uses.
M-2	Intended for higher-intensity industrial uses that should be separated from residential and commercial uses.
Other Districts	
P	Intended to provide areas for open space, recreation, and preservation of natural resources.
SF	Intended for State Fair grounds.

12.11 Zoning Map

The locations and boundaries of the Zoning Districts established by this Subchapter are set forth on the Official West Allis Zoning Map dated **TBD**, and as subsequently amended by action of the Common Council. The Zoning Map and all subsequent amendments, notations, references, and other information is incorporated by reference into this Subchapter and made part of this Subchapter, as if fully set forth herein. The map shall be kept on file in the office of the City Clerk and shall be available for inspection by the public during normal City Hall hours of operation. The Official Zoning Map shall be identified by the signature of the Mayor and attested by the City Clerk and bear the official seal of the City of West Allis.

Unless otherwise indicated in relation to established lines, points or features, the Zoning District boundary lines on the Official Zoning Map are the City limit lines; center lines of streets, highways, alleys or railroad right-of-way, existing or extended; and, tract or lot lines, existing or extended.

12.12 Split Zoning

Where a Zoning District boundary line runs approximately parallel to a street and divides a lot with street frontage in the less restricted Zoning District, the provisions of this Subchapter covering the less restricted portion of the lot may extend to the entire lot, but in no case more than 25 feet of such Zoning District boundary line. Where such Zoning District boundary line divides a lot with street frontage in a more restricted zone, the provisions of this Subchapter covering the more restricted portion of such lot shall extend to the entire lot. Where a Zoning District boundary line divides a lot and such line is normal or approximately normal to the street upon which the lot fronts, the provisions of this Subchapter covering the less or more restricted portion of such lot may be extended to the entire lot, but in no case more than 25 feet from such Zoning District boundary line.

12.13 C-1 and C-2 District Specific Conditions

The following conditions apply to all properties in the respective Zoning District:

Conditions	C-1	C-2
Display rack size (within 4 feet of window)	Max 50% window size	
Dwelling unit location	Not below second floor	
Interior wholesale, warehousing, and storage	Max 25% floor area	Max 25% floor area
Storefront Size	Min 10% floor area	Min 10% floor area

12.2 Uses

12.20 Zoning Use Determination

The Planning and Zoning Manager has the authority to classify uses on the basis of the use category, subcategory and specific use type descriptions of this chapter.

1. Determination of Substantially Similar Uses: When a use cannot be reasonably classified or appears to fit into multiple use categories, subcategories or specific use types, the Planning and Zoning Manager is authorized to determine the most similar and thus most appropriate use category, subcategory, or specific use.
 - a. This determination should be made based on the actual or projected characteristics of the principal use or activity in relationship to the use category, subcategory and specific use type descriptions provided in this chapter.
 - b. To make use determinations, the development administrator must consider:
 - i. The types of activities that will occur in conjunction with the use.
 - ii. The types of equipment and processes to be used.
 - iii. The existence, number and frequency of residents, customers or employees.
 - iv. Parking and loading and site improvement demands associated with the use.
 - v. Other factors deemed relevant to a use determination.

12.21 Principal Uses

The following table identifies the principal uses allowed in each Zoning District. Each use is given one of the following designations: P (Permitted Use), L (Limited Use), or C (Conditional Use). Uses without a designation are not permitted.

PRINCIPAL USE	RA-1	RA-2	RA-3	RB	RC	C-1	C-2	C-3	C-4	M-1	M-2	P	SF
Residential & Lodging													
1-Unit Dwelling	P	P	P	P	P		L	L	L				
2-Unit Dwelling	L	L	L	P	P		L	L	L				
3-4-Unit Dwelling				P	P	C	C	C	C				
Multi-Unit Dwelling (5 or more units)				C	P	C	C	C	C				
Bed and Breakfast	C	C	C	C	C								
Community Living Arrangement (8 or fewer persons)	P	P	P	P	P		P	P	P				
Community Living Arrangement (9 or more persons)				C	C		C	C	C				
Hotel/Motel						C		C	C	C	C		
Lodging House					C								
Residential Care	C	C	C	C	C		C	C	C	C	C		
Tourist Rooming House	P	P	P	P	P	L	L	L	L	L			

PRINCIPAL USE	RA-1	RA-2	RA-3	RB	RC	C-1	C-2	C-3	C-4	M-1	M-2	P	SF
Retail													
Neighborhood Retail						P	P	P	P	P	P		
General Retail								P	P	P	P		
Large Retail Development								C	C	C	C		
Alcohol Beverage Sales							P	P	P	P	P		
Nominal Price Retail Store									L				
Pawn Shop/Secondhand Jewelry Store									C				
Thrift Store									C				
Tobacco Retailer								L	L	L	L		
Service													
Neighborhood Service						P	P	P	P	P	P		
General Service								P	P	P	P		
Bar						P	P	P	P	P	P		
Restaurant						C	C	C	C	C	C		
Dry Cleaning								C	C	C	C		
Food Production (limited)						C	C	C	C	P	P		
Kennel										C	P		
Laundry (self-service)						C	P	P	P	P	P		
Massage Therapy						C	C	C	C	C	C		
Payday Lender									C	C	C		
Veterinary Clinic						C	C	P	P	P	P		
Civic & Institutional													
Civic Institution					C	C	C	C	C	C	C		
Family Day Care Home							C	C	C				
Funeral Home							C	C	C	C	C		
Live Event/Theater (less than 5,000 sq. ft.)					C	P	P	P	P	P	P		
Live Event/Theater (5,000 or more sq. ft.)						C	C	C	C	P	P		
Religious Institution	C	C	C	C	C		C	C	C	P	P	C	
Safety/Emergency Services										C	P		
School/Daycare	C	C	C	C	C		C	C	C	C	C	C	

PRINCIPAL USE	RA-1	RA-2	RA-3	RB	RC	C-1	C-2	C-3	C-4	M-1	M-2	P	SF
Parks & Recreation													
General Park	C	C	C	C	C	C	C	C	C	C	C	P	
Indoor Gun Range									P	P	P		
Instruction/Training Facility (15 or fewer persons)						P	P	P	P	P	P		
Instruction/Training Facility (16 or more persons)						C	C	C	C	C	C		
Recreation Facility (indoor)						C	C	C	C	P	P	P	
Recreation Facility (outdoor)										C	P	P	
Employment													
Office						P	P	P	P	P	P		
Employment Agency						P	P	P	P	P	P		
Workforce Development								C	C	C	C		
Manufacturing													
Commercial Light Industrial Flex								C	C	P	P		
Light Industrial										P	P		
Heavy Industrial											C		
Medical													
Hospital					C			C	C	C	C		
Medical Clinic						P	P	P	P	P	P		
Medical Service Facility								P	P	P	P		
Narcotic Treatment Service Facility									L	L	L		
Automotive													
Automobile Parts Sales								P	P	P	P		
Car Wash Service								C	C	C	L		
Fuel Sales							C	C	C	C	C		
Commercial Vehicle Dealing										C	P		
Commercial Vehicle Service											C		
Motor Vehicle Dealing (indoor)								C	C	C	P		
Motor Vehicle Dealing (outdoor)									C	C	P		
Motor Vehicle Service							C	C	C	C	C		

PRINCIPAL USE	RA-1	RA-2	RA-3	RB	RC	C-1	C-2	C-3	C-4	M-1	M-2	P	SF
Infrastructure													
Parking Lot/Structure										L	L		
Public Utility Service Structure (less than 25 sq. ft. and 6 ft. tall)	P	P	P	P	P	P	P	P	P	P	P	C	
Public Utility Service Structure (25 sq. ft. or 6 ft. tall or more)	C	C	C	C	C	C	C	C	C	C	C	C	
Substation Distribution and Equipment										C	P	C	
Wireless Communication Structure										C	C		
Other													
Adult Oriented Establishment								C	C	C	C		
Donation Center								C	C	C	C		
Mixed Use (commercial and residential)					C	C	C	C	C	C			
Research/Testing Laboratory and Technology Facility								C	C	C	P		
State Fair Use													P

12.22 Limited Use Criteria

The following section establishes the specific criteria that Limited Uses, as identified in Sec. 12.21, shall satisfy to be considered permitted.

1. Residential & Lodging

a. 1-Unit Dwelling

Commercial Districts	Permitted if located on a lot platted or recorded prior to the adoption of this ordinance which meets the minimum requirements of RB.
----------------------	---

b. 2-Unit Dwelling

Commercial Districts	Permitted if located on a lot platted or recorded prior to the adoption of this ordinance which meets the minimum requirements of RB.
Residential Districts	Permitted in RA-1, RA-2, and RA-3 on lots with a side or rear lot line adjacent to a lot in a commercial or manufacturing district. Common Council may grant exceptions for lots that share a side lot line with a lot adjacent to a commercial or manufacturing district.

c. Tourist Rooming House

Commercial Districts	Permitted if structure is a 1-Unit, 2-Unit, or 3-4 Unit Dwelling.
----------------------	---

2. Retail

a. Nominal Price Retail Store

Proximity	Permitted if located more than 1,000 feet from any lot where another Nominal Price Retail Store is located.
-----------	---

b. Tobacco Retailer

Proximity	Permitted if located at least 1,000 feet from any lot where the following are located: lots zoned P, Schools, Libraries, or another Tobacco Retailer or establishment licensed to sell any tobacco product or tobacco paraphernalia.
-----------	--

3. Medical

a. Narcotic Treatment Service Facility

Proximity	Permitted if located at least 250 feet from any lot where the following are located: lots zoned or developed for residential use, lots zoned P, Schools, or another Narcotic Treatment Service Facility.
-----------	--

4. Automotive

a. Car Wash Service

Proximity	Permitted if located at least 20 feet from any commercial lot line that abuts a lot located in a residential district.
-----------	--

12.23 Conditional Use Restrictions

The following section establishes restrictions for Conditional Uses, as identified in Sec. 12.21. If any of the following applies to the listed use, it shall be prohibited.

1. Retail

a. Pawn Shop/Secondhand Jewelry Store

Proximity	No Pawn Shop or Secondhand Jewelry Store shall be located within 3,500 feet from any lot where a Pawn Shop or Secondhand Jewelry Store is located.
-----------	--

2. Service Uses

a. Payday Lender

Proximity	No Payday Lender shall be located within 3,500 ft from any lot where a Payday Lender use is located.
-----------	--

3. Manufacturing Uses

a. Commercial Light Industrial Flex

	C-3	C-4
Proportion of Commercial Use	Not less than 20% floor area.	Not less than 10% floor area.

b. Heavy Industrial

	Asphalt, cement, stone processing, mixing or crushing uses	Waste and Recycling uses
Proximity	None within 500 feet from any property developed for nonindustrial uses.	None within 500 feet for any lots zoned or developed for any conforming residential use.

4. Automotive Uses

a. Car Wash Service

Proximity	No Car Wash shall be located within 20 ft of any commercial lot line that abuts a lot located in any residential district.
-----------	--

b. Fuel Sales

Proximity	No Automobile Convenience Store/Gas Station shall be located on a lot which directly shares a lot line with a lot zoned residential.
-----------	--

c. Motor Vehicle Dealing (outdoor)

Landscaping	Not less than 20% landscaping site coverage.
Lot Size	Not less than 1 acre.

d. Motor Vehicle Service

Proximity	No Automobile Repair/Service shall be located on a lot which directly shares a lot line with a lot zoned residential.
-----------	---

5. Infrastructure

a. Parking Lot/Structure

Requirements	See 12.42
--------------	-----------

b. Public Utility Service Structure

Location	Public utility service structures shall not be located within any front yard or corner side yard on private property.
----------	---

12.24 Accessory Use Table

The following table identifies the accessory uses allowed in each Zoning District. Each use is given one of the following designations: P (Permitted Use), L (Limited Use), or C (Conditional Use). Uses without a designation are not permitted.

ACCESSORY USE	RA-1	RA-2	RA-3	RB	RC	C-1	C-2	C-3	C-4	M-1	M-2	P	SF
Accessory Dwelling Unit	L	L	L	L	L		L	L	L				
Drive-Through						C	C	C	C	C	C		
Home Occupation	L	L	L	L	L	L	L	L	L	L			
Instruction/Training Facility (15 or fewer persons)						P	P	P	P	P	P		
Instruction/Training Facility (16 or more persons)						C	C	C	C	C	C		
Kennel						C	C	L	L	L	L		
Outdoor Dining						L	L	L	L	L	L		
Outdoor Sales/Display						C	C	C	C	C	C		
Outdoor Storage (including vehicles)								C	C	L	L		
Parking Lot/Structure					L	L	L	L	L	L	L	L	L
Production/Repair (less than 5,000 sq. ft.)						P	P	P	P	P	P		
Solar Energy System	P	P	P	P	P	P	P	P	P	P	P	P	P
Wind Energy System	C	C	C	C	C	C	C	C	C	C	C	C	C
Wireless Communication Collocation to Existing Structure	L	L	L	L	C	C	C	C	P	P	P	C	P

12.25 Accessory Use Criteria

The following section establishes the criteria that Limited and Conditional Uses, as identified in Sec. 12.25, shall satisfy to be considered permitted or conditional.

1. Accessory Dwelling Unit

Design	Fit to context of the site and neighborhood.
Entrance	If attached, must face away from street.
Number	Maximum 1 per lot.
Location	See 12.32
Height	See 12.32
Size	See 12.32

2. Home Occupation

Permitted Home Occupations, or other similar occupations with City approval, include the following (any occupation not specifically permitted is prohibited):		
Art studios	Family Day Care Home	Music lessons
Dental labs	Home Baking/Crafts	Office

3. Outdoor Storage (including vehicles)

Height	Loose materials shall not be stacked higher than 6 feet.
Location	Rear or side yard of lot.
Setback	Minimum 5 feet from any lot line or setback specified by zoning district regulation, whichever is greater.
Screening	Screened from view of adjacent lots and street right-of-way.
Shelter	Loose materials shall be stored in a 3- or 4-sided shelter and covered.

4. Parking Lot/Structure

Requirements	See 12.42
--------------	-----------

5. Wind Energy System

Abandonment	If out of service for continuous 2-year period, the Building Inspector may issue a notice of abandonment. The property owner shall have the right to respond within 30 days of notice. If still determined to be abandoned, the owner of the system shall remove within 30 days.
Access	Secured to prevent unauthorized access.
Automatic Over-Speed Controls	Equipped with over-speed controls to limit the blade rotation speed to within the design limits.
Electromagnetic Interference	Filtered to prevent emission of radio-frequency energy that would cause interference.
Height	Lowest part of blade minimum 8 feet from grade.
Lighting Arresters	Include properly grounded lighting arresters
Setback	Minimum 1 times the height from right-of-way, all lot lines, and any overhead utility lines.
Sound	Maximum 50 dB(A) at the property lines. If ambient sound is greater than 50 dB(A), sound produced shall be maximum 5 dB(A) above ambient sound level.

6. Wireless Communication Collocation to Existing Structure

	Residential Districts
Height (roof-mounted)	6 feet higher than principal structure
Height (ground-mounted)	Maximum 35 feet
Satellite Dish (ground-mounted)	Maximum 15 feet

12.3 Structures

12.30 Structure Regulations

The following table identifies the regulations for structures in each Zoning District. Additional use specific, residential accessory, and residential building feature regulations still apply.

	RA-1	RA-2	RA-3	RB	RC	C-1	C-2	C-3	C-4	M-1	M-2	P	SF
Maximum Floor Area Ratio					2.2	2.0	2.0	2.0	1.0	1.5	1.5		
Maximum Height	35'	35'	35'	40'								35'	
Maximum Lot Coverage (Interior Lot)	40%	40%	40%	60%									
Maximum Lot Coverage (Corner Lot)	45%	45%	45%	65%									
Minimum Lot Width	75'	50'	40'	30'									
Maximum Lot Width		150'	100'	80'									
Minimum Front Setback	30'	25'	20'	10'					10'	20'	30'	40'	
Maximum Front Setback			40'	30'		0'							
Minimum Rear Setback	25'	25'	10'	10'	10' *		10' *	10' *	10' *	10'	20'	40'	
Minimum Side Setback (East/South)	12'	10'	7'	7'	10' *		10' *	10' *	10' *		10'	40'	
Minimum Side Setback (North/West)	8'	5'	3'	3'	10' *		10' *	10' *	10' *		10'	40'	

*if abuts property with a conforming residential use, otherwise unrestricted.

12.31 Residential Accessory Building Regulations

Accessory buildings are permitted as a matter of right in all zoning districts established under this Subchapter and are subject to all applicable regulations set forth in this Subchapter. The following table identifies the regulations for residential accessory buildings.

	Accessory Dwelling Unit	Garage	Other Accessory Building
Maximum Height	20' exterior walls or height of principal structure (whichever is less)	18' or height of principal structure (whichever is less)	15'
Maximum Size	650 sq. ft. or 50% principal structure (whichever is less)	1,000 sq. ft.	150 sq. ft.
Minimum Setback from Principal Structure	10' *	10' *	10'
Minimum Front Setback	60' *	60' *	60'
Minimum Side/Rear Setback	3' *	3' *	3'
Minimum Alley Setback	5' *	5' *	5'

*Unless attached to principal structure. If attached, must adhere to appropriate bulk requirements found in Sec. 12.30.

12.32 Residential Building Feature Regulations

The following table identifies additional regulations for residential use 1- and 2- Unit Dwelling principal buildings and accessory buildings.

	Bay Window	Chimney	Ornamental Features	Roof Overhang
Minimum Distance to Lot Line	18"	18"		
Maximum Projection	3'	3'	18"	3'
Maximum Proportion of Yard Area	5%	5%		

12.33 Structures in Yards

Structures are permitted to be in required yards in accordance with the following table. Each structure is given one of the following designations: P (Permitted Structure), L (Limited Structure). Limited Structures shall be permitted upon meeting the specified limitations. Uses without a designation are not permitted.

Structure	Front Yard	Side Yard	Rear Yard	Limitations
Accessory Building	L	L	L	See 12.32
Air Conditioning Equipment		L	L	Minimum 1' from lot line
Animal House/Kennel			L	Minimum 5' from lot line
Basketball Hoop	P	P	P	
Canopy	P	P	P	
Cistern/Rain Barrel	P	P	P	
Compost Area		L	L	See 7.05(5)
Fence/Wall		L	L	See 13.30 and 13.31
Landscaping	P	P	P	
Open Accessory Off-Street Parking Space	P	P	P	
Patio	P	P	P	
Planter Box	P	P	P	
Play Equipment		P	P	
Porch	L	L	L	Maximum 15% of yard area, Minimum 10' from front lot line and 3' from side lot line
Refuse Container		P	P	
Retaining Wall	P	P	P	
Sign	L	L	L	See 13.21
Sporting Equipment		P	P	
Steps	P	P	P	
Swimming Pool		L	L	Minimum 3' from lot line
Wireless Communication Structure		P	P	See 12.26(7)
Yard Decorations	P	P	P	

12.4 Parking

12.40 Introductory Provisions

The intent of this Section is to provide and regulate accessory off-street parking and loading facilities to ensure an appropriate level of parking to support a variety of land uses, promote traffic safety, lessen traffic congestion, improve the aesthetics of the community, minimize adverse effects of off-street parking on adjacent properties, promote a clean, healthful environment and otherwise preserve and promote the public health, safety and general welfare and the intent and purposes of this Subchapter.

1. Applicability: All premises shall provide and maintain off-street parking and loading facilities for tenants, employees, and patrons of the principal use or uses in accordance with this Section and as hereafter specified.
 - a. Existing Premises and Uses: Existing premises shall maintain off-street parking and loading facilities in accordance with applicable zoning requirements in effect when the premise was occupied. The minimum construction and maintenance standards required in Sec. 12.43(1) shall apply to all off-street parking and loading facilities.
 - b. New, Altered or Changed Premises and Uses: No premise shall be created, altered, or changed to include new construction, enlarge an existing building or structure, or change the use, whether partial or wholly, unless provision is made for off-street parking and loading facilities as provided in this section. In case of any structural alteration to or enlargement of an existing building or structure or a partial change of use, Secs. 12.42, 12.43, 12.44, and 12.45 shall apply only to such alteration, enlargement, extension or change of use.

12.41 Motor Vehicle Parking Table

The following table identifies the number of required motor vehicle parking spaces for the given principal use.

Use		Maximum Number of Off-Street Parking Spaces
Residential & Lodging	1-or 2-Unit Dwelling	
	3 or more Unit Dwelling	2 per unit
	Community Living Arrangement	*
	Hotel/Motel and Bed and Breakfast	1.5 per guest room
	Lodging House	*
	Residential Care	1 per bed
Retail	All Retail Uses	3 per 1,000 square feet retail floor area
Service	Bar	*
	Restaurant	40% of capacity of persons
	All Other Service Uses	3 per 1,000 square feet service floor area
Civic & Institutional	All Civic & Institutional Uses	*
Parks & Recreation	All Parks & Recreation Uses	*
Employment	All Employment Uses	4 per 1,000 square feet
Manufacturing	Commercial Light Industrial Flex	3 per 1,000 square feet retail floor area plus 1 per employee
	All Other Manufacturing Uses	1 per employee
Medical	Hospital	*
	All Other Medical Uses	*
Automotive	Automobile Parts Sales	3 per 1,000 square feet retail floor area
	Motor Vehicle Dealing	*
	All Other Automotive Uses	*
Infrastructure	All Infrastructure Uses	*
Other	All Other Uses	*

* In accordance with site plan or special permit review

12.42 Motor Vehicle Parking Regulations

1. Minimum Construction Standards. All off-street parking, loading facilities and other site improvements shall be constructed and maintained in accordance with the following minimum standards and subject to Plan Commission approval in accordance with this section.

Curbing	Curbing or other approved method shall be installed so that no part of any vehicle shall extend beyond the lot line. Poured curbing, fencing, landscaping or other method shall be required where a parking lot and/or loading facility abuts a street, public right-of-way or building or as deemed appropriate by the Plan Commission.
Drainage	Graded and drained to provide for the collection of storm water on site with proper discharge to available public storm sewer or retention area and to prevent runoff onto adjacent lots and right-of-way. Paved areas and other site areas may be sheet drained to public right-of-way if approved by the City Engineer.
Landscaping	Provide a visual buffer, enclosure, and screening of site improvements from the City right-of-way and from adjacent properties to include, but not limited to, building foundations, paved parking and loading areas, permitted outdoor storage areas, utility boxes and other structures.
Large Parking Areas	Divide large, paved parking and loading areas into smaller areas of landscaped islands.
Lighting	Lighting used for illumination shall be so arranged to not reflect, direct or splay lighting beyond the property lines.
Refuse Areas	Enclosed to provide screening and containment of all refuse, waste and recyclables and containers. The enclosure shall be graded or curbed to direct runoff away from storm drains or surface waters, and into a suitable pervious area or sanitary sewer inlet.
Screening	All off-street parking and loading areas shall be effectively screened from any abutting lot by a solid screen, landscaping, wall or fence as approved by the Plan Commission.
Surface	Designed, constructed and maintained with macadam, concrete, sealcoat, paver blocks, permeable asphalt or concrete (subject to approval of the City Engineer), or similar suitable surface to eliminate dust, dirt and mud.

2. Driveway Permits: All off-street parking and/or loading facilities require a permit from the Board of Public Works to permit access to any improved or semi-improved street or alley in the City.
3. Handicapped Parking Spaces: The owner or lessee of any public building, place of employment, or parking facility which offers parking to the public shall reserve parking spaces for use by a motor vehicle used by a physically disabled person, in accordance with the provisions of Sec. 346.503 of the Wisconsin Statutes, and any administrative rules adopted as provided therein.
4. Shared Parking: Required parking spaces serving 2 or more premises may be located on the same lot or lots in the same structure. The joint use of parking spaces is authorized in the following situations:
 - a. All parking spaces located within 800 feet of the premises served.
 - b. There is appropriate parking provided for use throughout the day based upon the Motor Vehicle Parking Table found in 12.41.
 - c. Special use approval is required for the shared use of any parking spaces located in a residential zoning district.
5. Before imposing any vehicular parking requirements through the special permit process, the Plan Commission must consider evidence presented regarding: the possibility of multiple use reductions; the provision of bicycle parking; the proximity to transit stations or bus stops; the provision of on-site or nearby car share services; and transportation management plans promoting carpools, vanpools, subsidized transit passes, walking, biking, or regional ride sharing.
6. The Common Council may adjust the number of off-street motor vehicle parking spaces required in Sec. 12.41.

12.43 Bicycle Parking Table

The following table identifies the number of required bicycle parking spaces for the given principal use.

Use		Minimum Number of Short-Term Bicycle Parking Spaces	Minimum Number of Long-Term Bicycle Parking Spaces
Residential & Lodging	5+ Unit Dwelling	1 per 30 dwelling units (2 minimum)	1 per 5 dwelling units
	All Other Residential & Lodging Uses		
Retail	All Retail Uses	1 per 3,000 square feet	
Service	Private Safety/Emergency Service		
	All Other Service Uses	1 per 3,000 square feet	
Civic & Institutional	Family Day Care Home		
	School	1 per classroom	
	All Other Civic & Institutional Uses	1 per 10,000 square feet	1 per 15 employees
Parks & Recreation	All Parks & Recreation Uses	*	*
Employment	All Employment Uses	1 per 10,000 square feet	1 per 15 employees
Manufacturing	All Manufacturing Uses		1 per 15 employees
Medical	All Medical Uses	1 per 10,000 square feet	1 per 15 employees
Automotive	Automobile Parts Sales	1 per 3,000 square feet	
	Fuel Sales	1 per 3,000 square feet	
	All Other Automotive Uses		
Infrastructure	All Infrastructure Uses		
Other	All Other Uses	*	*

*In accordance with site plan or special permit review

12.44 Bicycle Parking Regulations

1. Long-Term Bicycle Parking Space Standards

Location	Indoors.
General Design	May be provided in a bicycle storage room, integral structured parking area, or other dedicated area located to provide direct access to an entrance a bicyclist may use. If not on ground floor, shall provide elevator or other reasonable means large enough to accommodate bicycles.
Exceptions	May be provided in an approved outdoor structure if the structure meets the accessory structure standards for the district in which it is located or if approved by Plan Commission.

2. Short-Term Bicycle Parking Space Standards

Location	Outdoors (within 100 feet of the entrance of the main occupancy served).
Dimensions	Minimum 2 feet in width and 6 feet in length.
General Design	A stationary device of metal tubing or stock which provides bicycle-locking points 1-3 feet off the ground and a gap near the bottom for pedal clearance. Shall be securely anchored to the ground or adjacent structure. A properly positioned inverted U-shaped rack shall be considered 2 bicycle parking spaces.
Location Exception	May be provided beyond 100 feet from the main entrance of the occupancy served in a location for the parking of multiple bicycles if 1 such space is located within 100 feet of the main entrance of the occupancy served.
Positioning	Shall be placed such that it does not interfere with pedestrian circulation, does not obstruct fire access routes or facilities, protects bicycles from damage, is readily visible to visitors, and minimizes visual clutter.
Securing of Bicycles	Shall provide 2 or more contact points between a bicycle and the rack. A bicycle rack which only allows securing of a wheel may not be used to meet the requirements of this section. The bicycle rack shall be designed to accommodate locking mechanisms, such as chain and U-shaped locking devices.
Surface	Shall be hard-surfaced, well-drained, and illuminated.
Exception	Any short-term bicycle parking spaces in the right-of-way within 100 feet of the main entrance of the occupancy served can be counted towards the short-term bicycle parking requirements.

3. Adjustment to Number of Spaces Required

- a. The Plan Commission may adjust the number of bicycle parking spaces required by Sec. 12.44.
- b. For an Employment or Manufacturing use, the required number of short-term bicycle parking spaces may be reduced by 50% for any portion of the occupancy above 240,000 square feet.
- c. For a Retail use, the required number of short-term bicycle parking spaces may be reduced by 50% for any portion of the occupancy above 36,000 square feet.
- d. No more than 20 short-term bicycle parking spaces shall be required for any individual Retail occupancy. However, this does not eliminate the requirement to provide a minimum number of bicycle parking spaces for other occupancies on the lot.

12.5 Planned Development

12.50 Overlay Districts

The Common Council of the City of West Allis may, with the consent of the owners, establish Overlay Districts for Planned Development.

Regulations in each Planned Development will promote the maximum benefit from coordinated area site planning, diversified location of structures and mixed compatible uses. Such regulations shall provide for a safe and efficient system for pedestrian and vehicular traffic, attractive recreation and landscaped open spaces, economic design and location of public and private utilities and common facilities and insure adequate standards of construction and planning. Such regulations may also provide for the development of the land in such Districts with one or more principal structures and related accessory uses and in such Districts the regulations need not be uniform.

Overlay Districts for Planned Development shall be classified as:

Overlay District	
PUD	Intended for planned unit residential, commercial, industrial, and mixed-use development.

12.51 Planned Development Procedures

1. Pre-Application: Prior to the formal submission of an application for a Planned Development, the developer and/or property owner shall confer with the Development Department to obtain information and direction on development plan requirements and procedures. The Development Department may also initiate the request for a Planned Development.
2. Application: Applications for a Planned Development shall be made in writing to the Common Council by filing with the City Clerk and shall include the following:
 - a. Name, address, and signatures of the applicant and/or owner, architect, planner, and professional engineer.
 - b. Preliminary development plan including maps, preliminary building plans and a written statement showing enough of the surrounding area to demonstrate the relationship of the proposed development to adjoining uses, both existing and proposed. The maps shall contain the following information:
 - i. Plat of survey prepared by registered land surveyor.
 - ii. Existing topographic features of the land and proposed grading changes.
 - iii. Existing and proposed land uses.
 - iv. Site plan.
 - v. Elevation and perspective drawings of all proposed structures and improvements.
 - c. Written statement which shall contain the following information:
 - i. Statement of present ownership of all lands in the proposed project.
 - ii. Statement of proposed financing.
 - iii. Statement restricting the project to be constructed, as proposed, with written agreement that the City does have the right to hold building permits for any or all of the project if it does not conform to the original proposal, unless changes have been mutually agreed upon.

- d. Development schedule which shall contain the following information:
 - i. Approximate construction start date.
 - ii. Construction stages and approximate start and completion dates.
 - iii. Agreements, provisions, or covenants which govern the use, maintenance, and continued operation of the planned development and any of its common open areas.
3. Review: Upon the formal submission of the application and fee for a Planned Development, the Common Council shall refer the application to the Plan Commission for review and recommendation. As a result of this recommendation, the Common Council shall establish a date for a public hearing.
 - a. Public hearing shall be held prior to any final action by the Common Council. Notice of public hearing shall be published as a Class II notice under Chapter 985 of the Wisconsin Statutes.
4. Determination: The Common Council may deny the petition, approve the petition as submitted, or approve the petition subject to additional conditions. Such approval shall constitute approval of the zoning change to impose this Overlay District and of the specific project development plan.
 - a. Approval
 - i. The approval of an application and consequent amending of the Zoning Map by overlay of this Overlay District shall be based on, and include as conditions thereto, the building, site, and operational plans for the development, as approved, as well as all other commitments offered or required as regard to project value, character or other factors pertinent to an assurance the proposed development will be carried out basically as presented in the official submittal plan. Detailed construction and engineering plans are conditioned upon the subsequent submittal to, and approval by, the Building Inspector.
 - ii. A subdivision development agreement relative to improvements shall be agreed with by the developer and the Board of Public Works.
5. Contract: The developer shall enter an appropriate contract with the City to guarantee the implementation of the development according to the terms of the conditions established as part of the development plan approval.
 - a. If no construction has begun or no permanent use has been established in the Planned Development within one year from the approval of the final development plan, the final development plan and related restrictions and conditions shall lapse and be of no further effect. In its discretion and for good cause, the Common Council may extend, for not more than one additional year, the period for the beginning of construction on the establishment of a permanent use. If a final development plan and related restrictions and conditions lapse under the provisions of this Section, the City Clerk shall file a notice of revocation with the Register of Deeds of Milwaukee County.
 - b. After approval of the Planned Development by the Common Council, the developer shall, at the time of application for building permits, pay a fee to the City Treasurer computed on the basis of \$300 per unit (residential, commercial or manufacturing). In the event the development consists of more than one billing or more than one phase, the fee shall be for those units for which a building permit is being requested and any credits due for fees previously tendered shall be on a proportional basis.
6. Failure to Begin Planned Development: If no construction has begun or no permanent use has been established in the Planned Development within one year from the approval of the final development plan, the final development plan and related restrictions and conditions shall lapse and be of no further effect.

- a. The Common Council may extend the period to begin construction or establish the permanent use up to 1 additional year. If a final development plan and related restrictions and conditions lapse under the provisions of this Section, the City Clerk shall file a notice of revocation with the Register of Deeds of Milwaukee County.

7. Changes and Amendments

- a. No changes shall be made in the approved final development plan and related restrictions and conditions during construction, except upon application under the procedures provided.
- b. Minor changes in location, setting, and height of structures may be authorized by the Plan Commission if required by circumstances not foreseen at the time of the final development plan.
- c. All other changes in use, rearrangement of lots, blocks, and building tracts, any changes in the provision of open spaces, and all other changes must be authorized by Common Council under the procedures authorized for approval of a Planned Development.
 - i. No amendments may be made in the approved final development plan or related restrictions and conditions unless they are shown to be required by changes that have occurred in conditions since the final development plans and related restrictions and conditions were approved or by a change in the development policy of the City.

8. Subdivision and Resale: A Planned Development shall not be subdivided or re-subdivided for purposes of sale or lease without the approval of the Common Council, as required in this Subchapter.

- a. All sections of a subdivided Planned Development shall comply with the final development plan and related restrictions and conditions, as approved by the Common Council, unless changes thereto have been approved in accordance with this Section.

9. Compliance: Upon any question related to compliance of an approved Planned Development, with the conditions and regulations as herein established and made specifically applicable to such development, the appropriate responsible party shall be given at least 15 days' notice to appear before the Plan Commission to answer such charge of noncompliance.

- a. If the Plan Commission finds the change substantiated and does not receive adequate assurance that the situation will be corrected within a reasonable time, as determined by the Plan Commission, it shall then recommend to the Common Council appropriate action to secure compliance or to revoke the approval of the development plan. Upon such revocation, no further building permits shall be issued within the project until approval has been reinstated in whole or part. In the case of failure to resolve the problem or to complete the development for any reason, the Common Council may require revision of the development plan to whatever degree is deemed necessary to achieve modified development with consideration of the specific problems of adjustment to the surrounding neighborhood consistent with the spirit and intent of the basic zoning regulations and of the original grant of the planned unit development approval.

12.52 Basis for Approval

1. Consistency: The proposed development is consistent with the spirit and intent of this Subchapter, is in conformity with the general character of the City and would not be contrary to the general welfare and economic prosperity of the City or of the immediate neighborhood. The benefits from improved design of the development justifies the variation from the normal requirements of this Subchapter through the application of a Planned Development.

2. Demonstrated Competent Planning: The proponents of the proposed development demonstrated that they intend to start and complete construction within a reasonable time period, have the financial capacity to carry out the project, and the project appears economically sound.
3. Compatibility with Surrounding Area: The size, quality, and architectural design of all buildings in the project will be compatible with the general character of the City and specifically the surrounding neighborhood. The following criteria shall be applied:
 - a. No building shall be permitted an unorthodox, abnormal, unsightly, or offensive design or exterior appearance in relation to the surroundings.
 - b. No individual building shall be permitted the design or exterior appearance that is so identical with the adjoining buildings that it creates excessive monotony and drabness.
 - c. No building shall be permitted without an exposed façade that is aesthetically compatible with other facades and presents an attractive appearance.
 - d. No building shall be permitted to be sited on the property in a manner which would unnecessarily destroy or damage the natural beauty of the area, particularly if it would adversely impact values incident to land ownership or the beauty and enjoyment of existing residence on adjoining properties.
4. Landscaping and Screening Bond: A surety bond or other form of security in the amount of 125% of the estimated cost of the landscaping and screening warranting and guaranteeing the landscape and screening plan as submitted and approved by the Plan Commission as part of the development. The bond shall be approved by the City Attorney prior to issuance of any building permits.
5. Commercial Developments
 - a. The economic practicality can be justified based on purchasing potential, competitive relationship, and demonstrated tenant interest.
 - b. The proposed development will be appropriately served by off-street parking and truck service facilities.
 - c. The locations for vehicular entrances and exits are designed to prevent unnecessary interference with the site, efficient movement of traffic, safety, accessibility for all road users, and will not create an adverse effect upon the general traffic pattern of the area.
 - d. The architectural design, landscaping, control of lighting and general site development will result in an attractive and harmonious service area compatible with and not substantially adversely impacting property values of the surrounding neighborhood.
6. Industrial Developments
 - a. The operational character, physical plant arrangement and architectural design of buildings will be compatible with contemporary performance standards and industrial development design and will not produce an effect upon the property values of the surrounding neighborhood substantially incompatible with that anticipated under the City's Comprehensive Plan for development.
 - b. The proposed development will have appropriate provisions for off-street parking and truck service areas and will be adequately served by rail or highway facilities.
 - c. The proposed development is properly related to the total transportation system of the community and will not produce an effect on the safety and efficiency of the public streets substantially incompatible with that anticipated under the City's traffic plans.
7. Mixed Use Developments
 - a. That the proposed mixture of uses produces a unified composite which is compatible within itself and is substantially compatible with the surrounding neighborhood and consistent with the general objectives of this Section.
 - b. That the various types of uses conform to the general requirements applicable to projects of such use character.



2021 Planning & Zoning Highlights



Take note!
Zoning code update expected in Q1 of 2022



Public Engagement

9 neighborhood meetings

25 public hearings



- 40 SLA approvals
- 18 SUP approvals
- 60 Properties rezoned
- 4 CSM approvals
- 100 Occupancies issued
- 49 Sign permits issued

Training & Professional Development
AICP, American Institute of Certified Planners
Open Gov (occupancy & sign permits)
SCORE Corp Award
(Revitalization & Collaboration – Open Gov)



3 Living Streets Murals



2021 Planning & Zoning Projects

