

50



City of West Allis Matter Summary

7525 W. Greenfield Ave.
West Allis, WI 53214

File Number	Title	Status
R-2006-0158	Resolution	In Committee
Communication from City Engineer regarding request from the West Allis Downtown Business District for a Minor Grant of Privilege.		
Introduced: 6/6/2006		Controlling Body: Public Works Committee

COMMITTEE RECOMMENDATION

Approve as Modified
ALLOW HANGING BASKETS, NOT ALLOW PLANTS

ACTION DATE:	MOVER	SECONDER		AYE	NO	PRESENT	EXCUSED
<u>6-6-06</u>			Barczak				
			Czaplewski				
			Dobrowski	✓			
			Kopplin				✓
			Lajsic				
			Narlock	✓			
			Reinke				
		✓	Sengstock	✓			
	✓		Vitale	✓			
			Weigel				
			TOTAL	<u>4</u>			<u>1</u>

SIGNATURE OF COMMITTEE MEMBER

[Signature] _____
 Chair Vice-Chair Member

COMMON COUNCIL ACTION

APPROVAL AS amended

ACTION DATE:	MOVER	SECONDER		AYE	NO	PRESENT	EXCUSED
<u>JUN 06 2006</u>			Barczak	✓			
			Czaplewski	✓			
			Dobrowski	✓			
			Kopplin				✓
	✓		Lajsic	✓			
			Narlock	✓			
			Reinke	✓			
		✓	Sengstock	✓			
			Vitale	✓			
			Weigel	✓			
			TOTAL	<u>9</u>			<u>1</u>



CITY OF WEST ALLIS

WISCONSIN



Engineering Department

MICHAEL G. LEWIS
City Engineer

Memorandum

TO: Richard Narlock, Chair, Board of Public Works
Vincent Vitale, First District
Kurt Kopplin, Second District
Linda Dobrowski, Fourth District
James Sengstock, Fifth District

FROM: Michael Lewis, City Engineer

DATE: June 1, 2006

RE: **Communication from City Engineer Regarding Request from the West Allis Downtown Business District for a Minor Grant of Privilege**

Alderman Kurt Kopplin asked that this be placed on the agenda. You have received a memo from Michael Pertmer on his concerns.

Minor Grant of Privilege is usually handled administratively. But because of the issues involved in this request, we wanted approval from the Board.



CITY OF WEST ALLIS

WISCONSIN



Engineering Department

MICHAEL G. LEWIS
City Engineer

Memorandum

TO: Richard Narlock, Chair, Board of Public Works
Vincent Vitale, First District
Kurt Kopplin, Second District
Linda Dobrowski, Fourth District
James Sengstock, Fifth District

FROM: Michael Lewis, City Engineer

DATE: May 16, 2006

RE: **Grant of Privilege for Steel Fencing from Downtown Business District**

We received the attached request for steel fencing from the BID. This idea was e-mailed to a number of Departments by Planning/Development. The City Attorney's Office, Public Works and Engineering Departments were concerned about the potential of injuries and maintenance. These fences would be considered a minor encroachment, since they can be easily removed, and can be approved by the City Engineer. But before I sign off on this, I want to find out the feelings of the Board of Public Works. If any members want me to hold off and place this on the next available agenda, please contact me. If I don't hear from anyone by Friday, May 19th, I will approve the BID's request.

Cc: Michael Pertmer, Director of Public Works



CITY OF WEST ALLIS

WISCONSIN



Public Works Department

MICHAEL PERTMER
Director

To: Michael Lewis, City Engineer
From: Mike Pertmer, Director of Public Works *MP*
Re: Grant of Privilege for Steel Fencing in BID
Date: May 17, 2006

In response to your memo to the members of the Board of Public Works regarding the Grant of Privilege for Steel Fencing around the street trees in the Downtown Business District, I again must reiterate my concerns with this proposal. I feel that the relatively narrow sidewalk space (9' from curb face to building) does not lend itself to this type of structure. They will create a tripping hazard with the potential of a person falling and impaling themselves on one of the steel posts. In addition, these structures appear to be within 12 inches of the curb on the street side. Some passenger in a car parking at the curb will, inevitably, be oblivious to these structures and swing a car door open into the steel causing damage to the car door.

I am also concerned with the maintenance problems these structures will cause. Cigarette butts, and other trash will inevitably collect inside the structures. Clearing this debris will be an on-going problem. That problem will be enhanced if the area is planted with vegetative matter.

The planting of flowers along the base of these trees with or without a structural barrier has always been a concern of mine. Obviously there is very limited surface area to absorb rain and nutrients needed by both the surface plant materials and trees. In short, the trees and the surface plantings are in competition for the same thing generally resulting in stress for both.

Finally, I have noted that it is the BID's intention to remove these structures during the winter months. I have two concerns related to this. First, I have concerns with the BID driving six support posts into the ground every year. There is a high likelihood for damage to the tree roots not to mention to the electrical cable behind the curb. Second, I have some concern as to who will be removing, hauling and storing these steel structures during the winter months. Public Works cannot afford to get involved with this.

In conclusion, as part of the grant of privilege, at a minimum I would require daily maintenance of the enclosed barrier including but not limited to litter and weed removal within the barrier. Second, there should be a stipulation that if a street tree dies as a result of root injury caused by the placement of the structure, the BID be responsible for all costs removing and replanting the tree.

Thank you for your consideration of these issues.

CC: Ald. Narlock, Vitale, Kopplin, Dobrowski, Sengstock

MEMORANDUM

RECEIVED

MAY 15 2006

CITY OF WEST ALLIS
ENGINEERING DEPT.

TO: Michael Lewis, City Engineer

FROM: Sharon R. Lesak, Real Estate Agent *SRL*

DATE: May 15, 2006

SUBJECT: Grant of Privilege - Address: Greenfield Avenue Between S. 70
and S. 76 Streets

Owner: Downtown West Allis Business
Improvement District

Tax Key: Various

Attached is information received regarding applicant's request that a "Grant of Privilege" be approved for the placement of fencing around the perimeter of the street level planter beds and installing handing baskets on the three interior light poles located on both sides of West Greenfield Avenue between South 70th and 76th Streets.

The application has been forwarded to Ted Atkinson and Terry Tauschmann for review and comments. If you approve this encroachment, please have your department's surveyor supply us with a legal description as soon as possible.

Thank you for your cooperation in this matter.

SRL:da

Attachment

C/GrantPrv-City Engineer

cc: Ted Atkinson (Attach.)
Terry Tauschmann (Attach.)
Leo Kos (Attach.)



DOWNTOWN WEST ALLIS BUSINESS IMPROVEMENT DISTRICT

7231 West Greenfield Avenue • Suite 201 • West Allis, Wisconsin 53214 • (414) 774-2676 • Fax (414) 774-7728
www.downtownwestallis.com

May 12, 2006

Board of Public Works
City of West Allis
7525 W. Greenfield Ave.
West Allis, WI 53214

RECEIVED
MAY 15 2006
WEST ALLIS
CITY ATTORNEY

I am writing to ask your permission to use the public right of way as it pertains to the "Large" street level planter beds for the purpose of placing fencing around the perimeter and installing hanging baskets on the three interior light poles located on both sides of Greenfield Ave. between 70th & 76th Street. We intend to remove the fencing and the hanging baskets between Thanksgiving and April 1st.

Please find pictures of the fencing, when it was temporarily installed in front of George Webb's 7227 W. Greenfield Avenue, and the fencing specifications attached.

Presently we are exploring using 15" diameter cast aluminum hanging baskets. Artificial flowers will be placed in these baskets. The brackets, used to hang the baskets, would be extending East and West of the light poles.

Please find the bracket specifications along with a picture of the proposed Baskets attached.

The BID is continuing to improve the aesthetics of the downtown. Since the inception of the Streetscape project in 2003, we have been exploring methodologies regarding the appropriate plant species and proper maintenance procedures for the variations in soil condition, exposure to sunlight and salt on both sides of Greenfield Ave. The first two years of planting was done by the City of West Allis Forestry Department. The third year the BID took on this responsibility. Neither group have been able to obtain acceptable results.

The design and placement of these large planters are not conducive to a consistent plant growth or protection from erosion and pedestrian traffic. See picture attached depicting the pedestrian and erosion issue. It is our opinion that without a barrier such as the proposed fencing a manageable and aesthetic planter bed will not be achievable.

Hanging baskets has been an effective tool to present a colorful and natural look to the downtown. Hanging baskets in other Main Street Communities have proven to be a major component in attracting pedestrian traffic to these business districts. We had considered using real flowers but the expense and intensive labor maintenance eliminates this method.

We would like to install the fencing and hanging baskets this spring/summer.

Thank you for your consideration of our proposal. Please do not hesitate to contact me with any questions

Best regards,

Brian Kreiss
Executive Director

Downtown West Allis Business Improvement District

A Main Street Community **Managed by Downtown West Allis, Inc.** **A 501c3 Non-Profit Corporation**
Building a positive image that encourages customer growth and welcomes community involvement.

** Review Sat May 13*



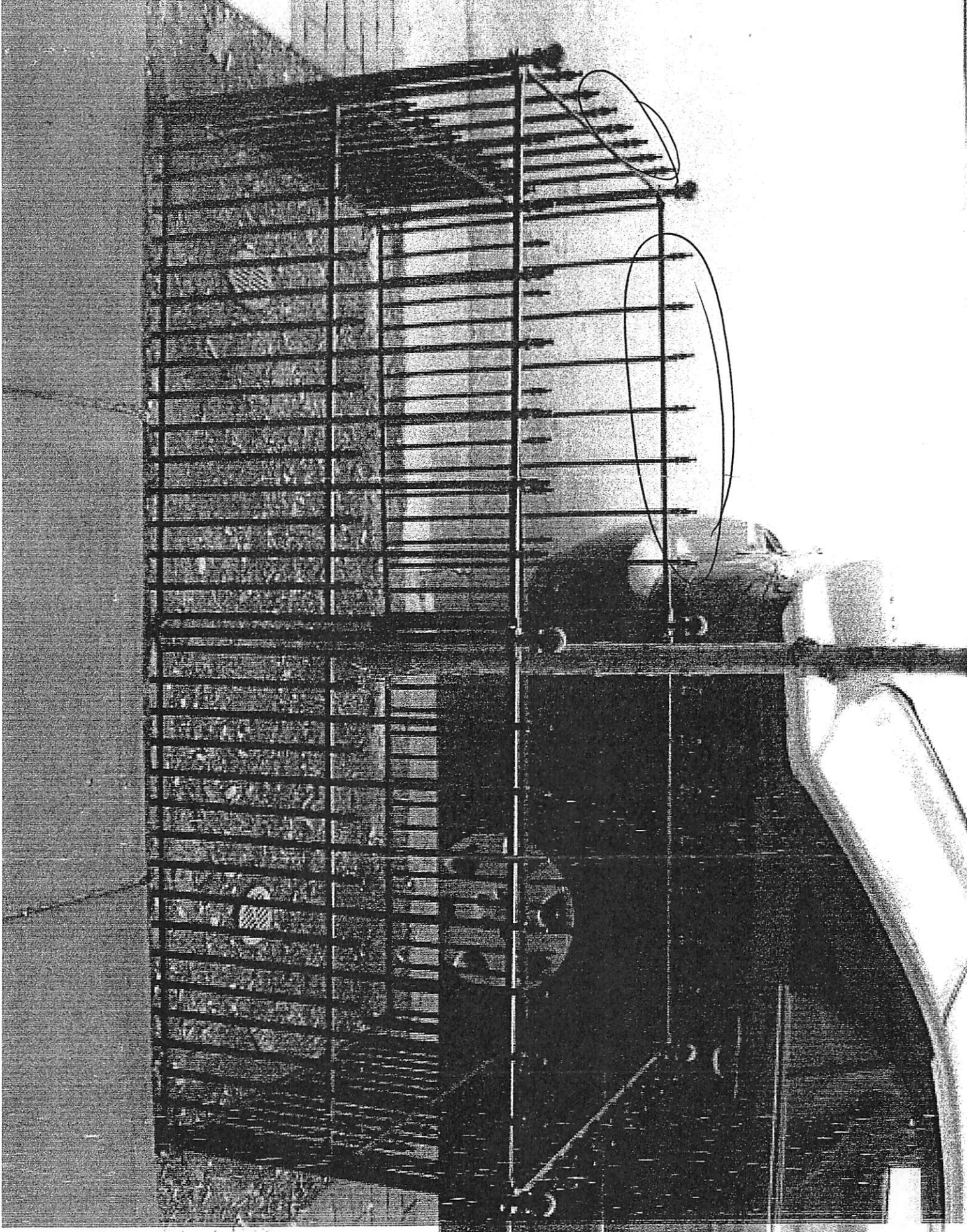

GARDEN ZONE

- Graceful classic design
- Easy modular assembly
- Coated finish for durability
- Heavy welded steel

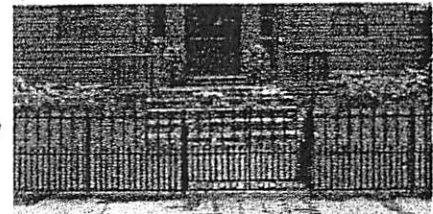

HOME

ABOUT GZ

PRODUCTS

FENCES

EMPIRE

GRAND EMPIRE

WELDED WIRE FENCE

SPECIAL USE FENCE

GZ TIPS

RETAILERS

CONTACT GZ

INSTALLATION TIPS

SUGGESTED USES

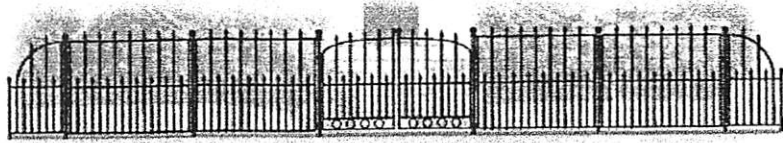

End Unit Base Unit Gate Unit 41" Posts & Stakes used with Empire Fence

EMPIRE DECORATIVE FENCE

PROD NO	SIZE	PRODUCT & SIZE	COLOR	PK
061115	29" x 36"	BASE UNIT	Black	4
061160	29.5" x 45.5"	GATE UNIT	Black	4
061139	30.5" x 17.75"	END UNIT	Black	4
061153	41.25"	POST & STAKE	Black	16

[Home](#)
 [About GZ](#)
 [Products](#) ▾
 [GZ Tips](#) ▾
 [Retailers](#) ▾
 [Contact GZ](#) ▾

All images and content on this site (except where noted) are the property of Garden Zone LLC.

All Rights Reserved. Images and content cannot be legally copied, altered, displayed or distributed without the express written permission of Garden Zone LLC.

© Copyright 2006



650 S. 108th St.
WEST ALLIS WI 53214
Phone: 414 / 607-7700
Fax: 414 / 778-1873

To: CITY OF WEST ALLIS
7525 W GREENFIELD AVE
WEST ALLIS WI 53214
Attn: STEVE SCHEAR
Phone: 414-302-8302
Fax: 414-302-8321
Email: rbarwick@ci.west-allis.wi.us

Date: 02/15/2006
Proj Name:
GB Quote #: 202335093
Valid From: 12/19/2005
Valid To: 03/15/2006
Contact: CHRIS MEISTER
Email: Chris.Meister@gbe.com

Proposal

We Appreciate Your Request and Take Pleasure in Responding As Follows

Item	Quantity	Supplier	Catalog Nbr	Description	Price	Unit	Ext.Price	
100	50	HOLOPHANE AN NOF ACUITY LIGHTING	PBA20R1C0/xx/S/RA L6005	DATE DOT TO E10 OF ARM 3-AWK. LDTIME	313.95	1	15,697.50	
Signed: _____							Total (Tax not included):	15,697.50

Terms and Conditions of sale:

- 1. ACCEPTANCE OF ORDER; TERMINATION** - Acceptance of any order is subject to credit approval and acceptance of order by Seller and, when applicable, Seller's suppliers. If Buyer's credit becomes unsatisfactory to Seller, Seller reserves the right to terminate upon notice to Buyer and without liability to Seller.
- 2. PRICES AND SHIPMENTS** - Unless otherwise quoted, prices shall be those in effect at time of shipment which shall be made F.O.B. shipping point.
- 3. RETURN OF GOODS** - Credit will be allowed for goods returned with prior approval. A deduction will be made from credits issued to cover cost of handling.
- 4. TAXES** - Prices shown do not include sales or other taxes imposed on the sale of goods. Taxes now or hereafter imposed upon sales or shipments will be added to the purchase price. Buyer agrees to reimburse Seller for any such tax or provide Seller with an acceptable tax exemption certificate.
- 5. DELAY IN DELIVERY** - Seller is not to be accountable for delays in delivery occasioned by acts of God, failure of its suppliers to ship or deliver on time or other circumstances beyond Seller's reasonable control. Factory shipment or delivery dates are the best estimates of our suppliers, and in no case shall Seller be liable for any consequential or special damages arising from any delay in shipment or delivery.
- 6. WARRANTIES** - Seller warrants that all goods sold are free of any security interest and will make available to Buyer all transferable warranties made to Seller by the manufacturer of the goods. SELLER MAKES NO OTHER EXPRESS OR IMPLIED WARRANTIES AND SPECIFICALLY MAKES NO IMPLIED WARRANTIES OF MERCHANTABILITY OR FITNESS FOR PURPOSE. UNLESS OTHERWISE AGREED IN WRITING BY AN AUTHORIZED REPRESENTATIVE OF SELLER, PRODUCTS SOLD HEREINAFTER ARE NOT INTENDED FOR USE IN OR IN CONNECTION WITH A NUCLEAR FACILITY.
- 7. LIMITATION OF LIABILITY** - Buyer's remedies under this contract are subject to any limitations contained in manufacturer's terms and conditions to Seller, a copy of which will be furnished upon written request. Furthermore, Seller's liability shall be limited to either repair or replacement of the goods or refund of the purchase price, all at Seller's option, and in no case shall Seller be liable for incidental or consequential damages. In addition, claims for shortages, other than loss in transit, must be made in writing not more than five (5) days after receipt of shipment.
- 8. WAIVER** - The failure of Seller to insist upon the performance of any of the terms or conditions of this contract or to exercise any right hereunder shall not be deemed to be a waiver of such terms, conditions or rights in the future, nor shall it be deemed to be a waiver of any other term, condition, or right under this contract.
- 9. MODIFICATION OF TERMS AND CONDITIONS** - No terms and conditions other than those stated herein, and no agreement or understanding, in any way purporting to modify these terms or conditions, shall be binding on Seller without the Seller's written consent. Any additional or different terms in the buyer's form are hereby deemed to be material alterations and notice of objection to them and rejection of them is hereby given.
- 10. REELS** - When the Seller ships returnable reels, a reel deposit will be included in the invoice. The Buyer should contact the nearest Graybar service location to return reels.

This equipment and associated installation charges may be financed for a low monthly payment through Graybar Financial Services (subject to credit approval). For more information call 1-800-241-7408 to speak with a leasing specialist.

To learn more about Graybar, visit our website at www.graybar.com

24-Hour Emergency Phone#: 1-800-GRAYBAR

Subject to the standard terms and conditions set forth in this document.

Planter Banner Arms (PBA) - Aluminum and Steel

MOUNTING DETAILS

Bolt-On Mounting

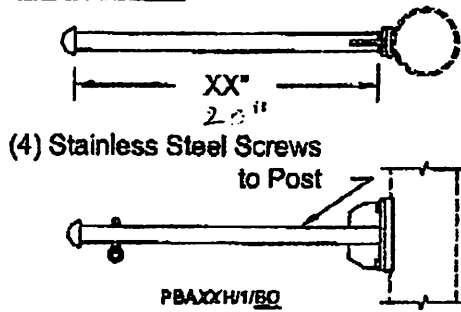

(4) Stainless Steel Screws to Post

Clamp On Mounting

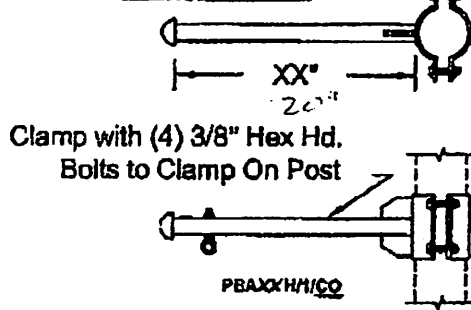

Clamp with (4) 3/8" Hex Hd. Bolts to Clamp On Post

SUGGESTED PLANTER BANNER ARM USAGE

PBA24B/BO*
(Planter Arm, 24", Ball end cap / 1" Ø / Bolt On)

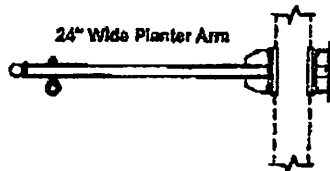

NOTE:
*For two planter arms add a 2 before the part no. (2PBA24B/BO-EB-...)

PBA18R/CO2(180)S-EB-XX-XX/XX
(Planter Arms, 18", Raleigh end cap / 1" Ø / Clamp On, 2 arms at 180°, 5" Ø post shaft, eye-bolt with length from end cap, CA (aluminum) or S (steel) / XX (paint finish)

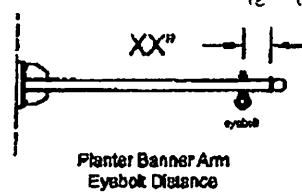
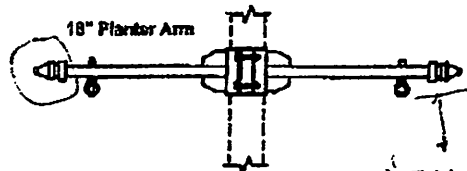

NOTE:

- For information on specifying orientation and mounting heights see Orientation Guide in the back of the Accessories section in the catalog.
- A maximum weight on the aluminum planter arm is 75 pounds, steel arms can go higher. Windload required on all arms.
- Planters are not supplied by Holophane.

ORDERING GUIDE	sample catalog number	planter banner arm, end cap / Arm Ø / mounting option	eye-bolt-distance-material / finish
	PBA24H/BO-EB-2-CA/BK	PBA24 H / 1 / BO	-EB-2 -CA/BK
Planter Banner Arms (fill in ___ with desired arm length in inches)	Planter Arm Diameters	Options	
PBA ___ Std. Planter Banner arm	<input type="checkbox"/> 1 Std. 1" Pipe (1.32" O.D.)	<input type="checkbox"/> 1S Decorative Scroll On Arm	
	<input type="checkbox"/> 1.25 1 1/4" Pipe (1.66" O.D.)	Required (fill in ___ with diameter of post shaft, or clamp, in inches)	
	<input type="checkbox"/> 1.5 1 1/2" Pipe (1.90" O.D.)	<input type="checkbox"/> -EB-___ Eye-bolt and distance from end cap	
Planter Arm End Caps	Mounting Options	Material / Finish	
<input type="checkbox"/> H Std. Half Sphere Cap	(fill in ___ with diameter of post shaft, or clamp, in inches)	<input type="checkbox"/> -CA or S /BK Cast Alum. or Steel/Black (Std.)	
<input type="checkbox"/> B Ball Cap	<input type="checkbox"/> BO Bolt On (Bolts onto Post)	<input type="checkbox"/> -CA or S /DB Cast Alum. or Steel/Dark Bronze	
<input type="checkbox"/> A Acom Cap	<input type="checkbox"/> CO Clamp On (Clamps around Post)	<input type="checkbox"/> -CA or S /DG Cast Alum. or Steel/Dark Green	
<input type="checkbox"/> R Raleigh Cap	<input type="checkbox"/> CO2(180) Clamp On (two arms at 180°)	<input type="checkbox"/> -CA or S /CM Cast Alum. or Steel/Cust. Match	
	<input type="checkbox"/> CO2(90) Clamp On (two arms at 90°)	<input type="checkbox"/> -CA or S /CS Cast Alum. or Steel/Cust. Select.	
	<input type="checkbox"/> CO3(90) Clamp On (three arms at 90°)	<input type="checkbox"/> -CA or S /PP Cast Alum. or Steel/Prime Painted	
	<input type="checkbox"/> CO4(90) Clamp On (four arms at 90°)		



Planter Banner Arm Aluminum and Steel

ORDER #:	TYPE:	DRAWING #:
REVISION:	REVISION DATE:	TSG 000679
DRAWN: ACH	ORIGIN DATE: 10-06-05	PAGE: 2

THIS DRAWING, BEING APPROVED, SHALL BECOME THE COMPLETE SPECIFICATION FOR THE MATERIALS TO BE FURNISHED BY HOLOPHANE FOR THE ORDER NOTED ABOVE. A COPY OF THIS DRAWING SHOULD BE OBTAINED BY THE BUYER BEFORE ANY ORDER IS PLACED. THE PROPERTY OF HOLOPHANE AND IS LOANED SUBJECT TO RETURN UPON DEMAND AND UNDER EXPRESS CONDITION THAT IT WILL NOT BE USED DIRECTLY OR INDIRECTLY IN ANY WAY DETRIMENTAL TO OUR INTERESTS, AND ONLY IN CONNECTION WITH MATERIALS FURNISHED BY HOLOPHANE.



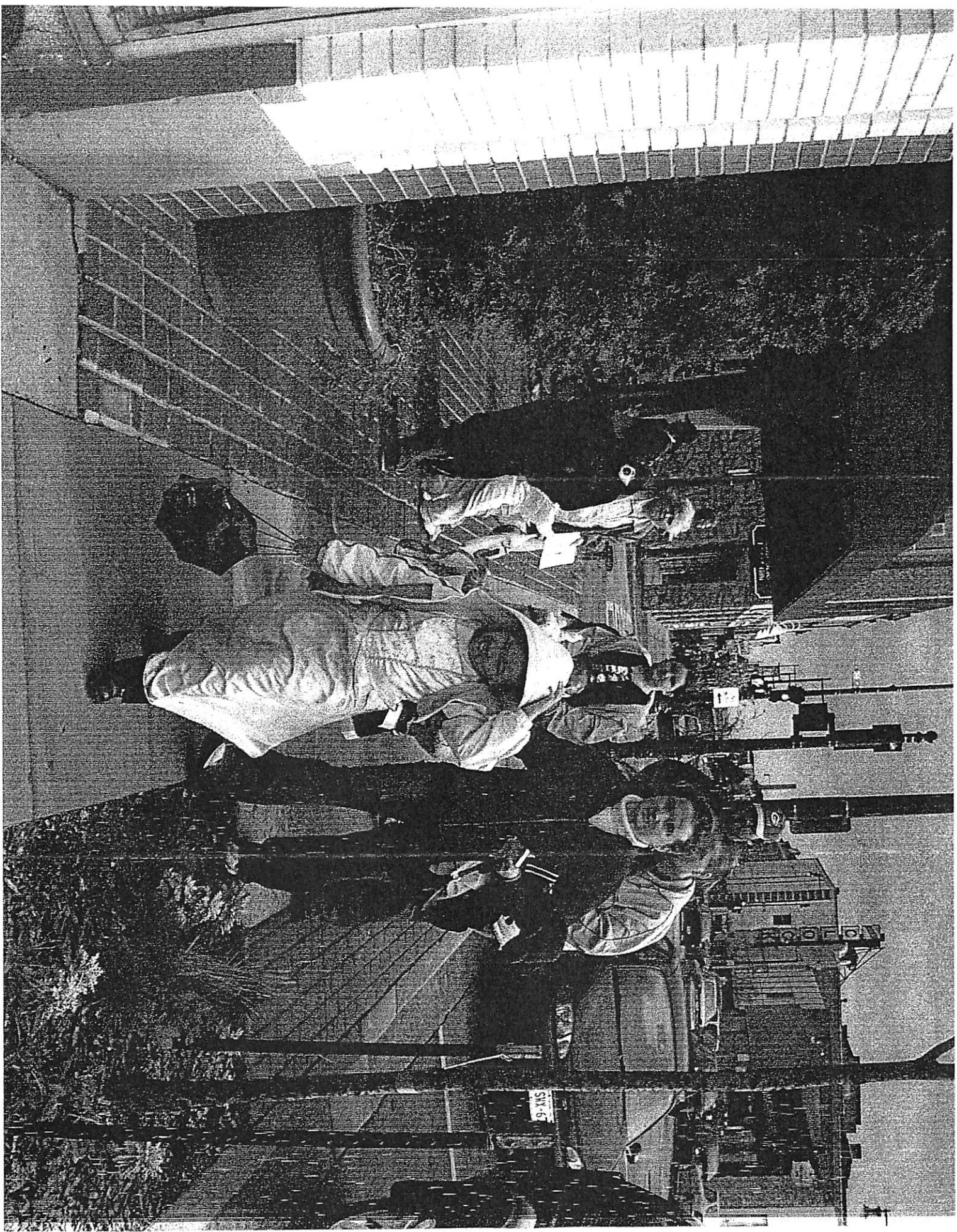

Sharon Lesak

From: Steve Schaer
Sent: Tuesday, April 18, 2006 2:24 PM
To: Sharon Lesak
Subject: decorative fences

Sharon,

Please send Brian Priess a copy of the minor encroachment permit. The BID wishes to install decorative fences around some of the planter beds in the downtown. The BID is also considering hanging baskets from some of the street lights. What is the level of insurance coverage needed? There will be up to 20 fence locations around existing planter beds and up to 50 hanging baskets (At height of 10 ft.) in the downtown.

see attached example.



CIMG3636.JPG



street light.jpg

Steven J. Schaer, AICP
Manager of Planning and Zoning Division
City of West Allis
(414) 302-8466